

AHE 无线温湿度传感器
AHE Temperature and humidity Sensor

安装说明 V1.3
Installation Instruction V1.3

申 明

DECLARATION

版权所有，未经本公司之书面许可，此手册中任何段落，章节内容均不得被摘抄、拷贝或以任何形式复制、传播，否则一切后果由违者自负。

All rights reserved. No part of this publication may be reproduced, stored in a retrieval system, or transmitted in any form by any means, electronic, mechanical photocopying, recording, or otherwise without prior permission of our company. The violator will bear the dependent legal responsibility.

本公司保留一切法律权利。

We reserve all the rights.

本公司保留对本手册所描述之产品规格进行修改的权利，恕不另行通知。

We reserve all the rights to revise product specification without notice.

订货前，请垂询当地代理商以获悉本产品的最新规格。

Please consult local agent to get the latest information of our products specification.

目 录

Table of Contents

1 安装指南	1
1 Installation Guide	1
1.1 产品概述	1
1.1 Product Introduction	1
1.2 技术指标	1
1.2 Technical Features	1
1.3 产品安装	2
1.3 Product Installation	2
1.4 无线温湿度传感器收发器	4
1.4 Wireless temperature and humidity sensor Coordinator	4
1.5 方案配置	5
1.5 Scheme configuration	5

1 安装指南

1 Installation Guide

1.1 产品概述

1.1 Product Introduction

AHE100 无线温湿度传感器主要用于中高压开关柜、端子箱、环网柜、箱变等设备内部及配电室环境的温湿度的检测。模块采用专用外壳，通风效果好，外观精致，能有效保护内部元件，提高使用寿命。

AHE100 temperature and humidity sensor is mainly used to detect the internal temperature and humidity of medium and high voltage switchgear, terminal box, ring network cabinet, box transformer and other equipment. The module adopts a special shell with good ventilation effect and exquisite appearance, which can effectively protect internal components and improve service life.

1.2 技术指标

1.2 Technical Features

技术参数 Items		指标 Features
测量范围 Range	温度 Temperature	-30℃~85℃
	湿度 Humidity	0~100%RH
精度 Precision	温度 Temperature	±1℃
	湿度 Humidity	±3%RH
采集频率 Acquisition frequency		25S
发射频率 Transmitting frequency		电池供电：5Min(5Min 内温度变化 $\geq 2^{\circ}\text{C}$ 或湿度变化 $\geq 5\%\text{RH}$ 时提前上报) Battery-powered for 5 minutes (reported in

	advance when the temperature changes within 5 minutes $\geq 2^{\circ}\text{C}$ or the humidity changes $\geq 5\%\text{RH}$
	电源 DC(12-48)V 供电: 25S Power supply (12-48)V: 25S
安装方式 Installation mode	导轨式 Guide rail installation
供电方式 Power supply mode	电池供电, 使用寿命 3 年 (25°C 环境下), 可更换 (型号 CR2450) Battery-operated, 3 years service life (25°C), replaceable (Model CR2450)
	DC(12-48)V
传输距离 Communication distance	电池型传输距离 500m(空旷) Battery-type transmission distance: 500m (open)
	DC(12-48)V 供电传输距离 1000m (空旷) DC(12-48)V power supply transmission distance: 1000m (open)

1.3 产品安装

1.3 Product Installation

1.3.1 电池供电

1.3.1 Battery-powered

AHE100 无线温湿度传感器, 采用导轨 (DIN35mm) 安装方式, 使用前需打开电池开关。

AHE100 temperature and humidity sensor is installed by guide rail (DIN35mm). It is necessary to turn on the battery switch before use.

1 —— 无线温湿度传感器主体

1 —— Wireless temperature and humidity sensor body

2 —— 电池开关

2 —— Power switch

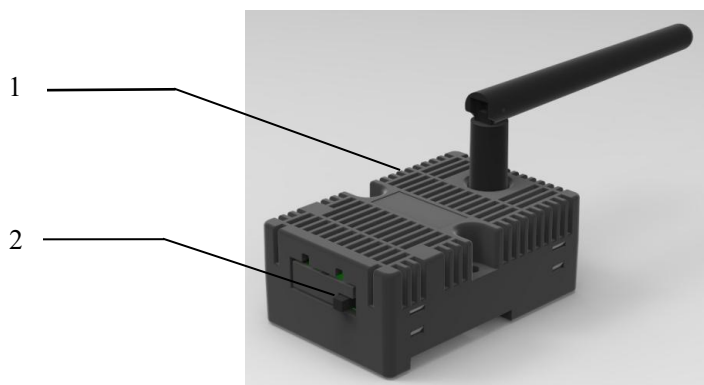

1.3.2 电源供电

1.3.2 Power supply

AHE100 无线温湿度传感器，采用导轨（DIN35mm）安装方式，使用前需将电源端子插接良好。
 AHE100 wireless temperature and humidity sensor, using rail (DIN35mm) mounting method, the power terminal needs to be well plugged in before use.

- 1 —— 无线温湿度传感器主体
- 1 —— Wireless temperature and humidity sensor body
- 2 —— 电源端子
- 2 —— Power terminals

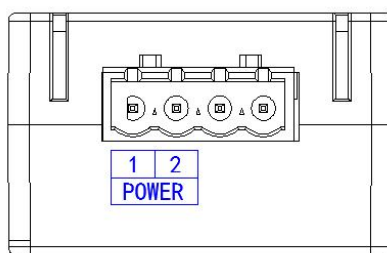
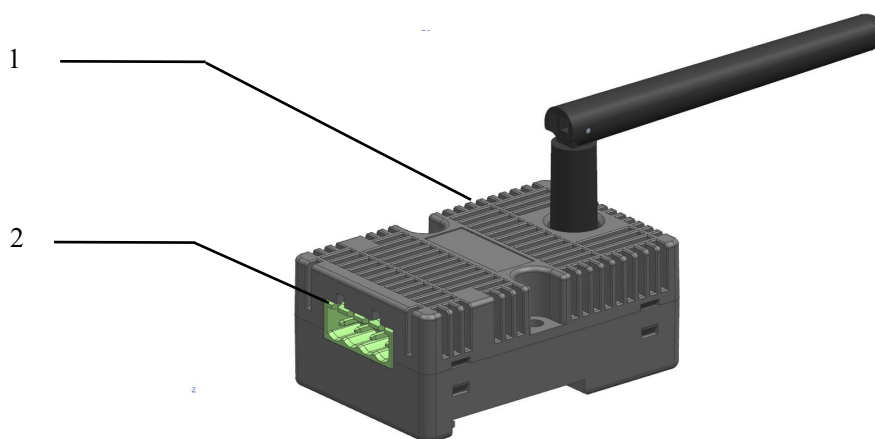

接线端子图
 Terminal block diagram

1.3.3 外形尺寸

1.3.3 Shape Size

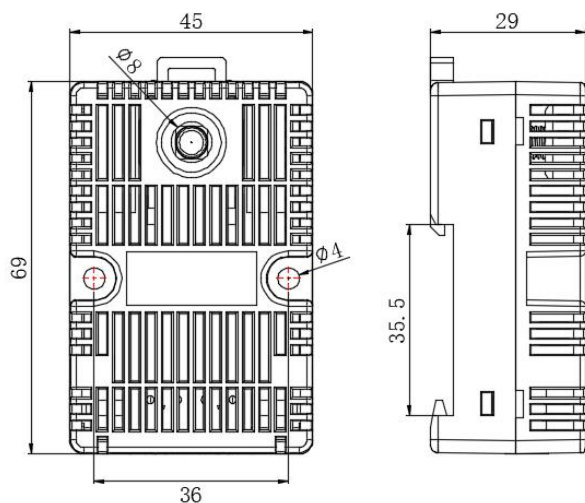

温湿度传感器

Temperature and humidity sensor

1.4 无线温湿度传感器收发器

1.4 Wireless temperature and humidity sensor Coordinator

与 AHE100 无线温湿度传感器配套使用的无线温度收发器 ATC600-C，可以采用导轨（DIN35mm）安装方式。

The wireless temperature coordinator ATC600 used with AHE100 wireless temperature and humidity sensor can be installed by guide rail (DIN35mm).

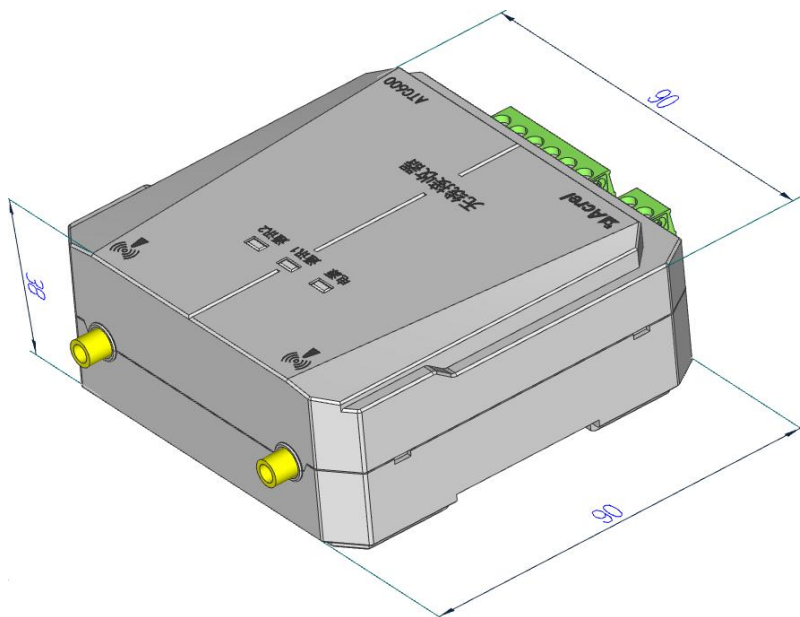

1.5 方案配置

1.5 Scheme configuration

触摸屏搭配 ATC600-C:

HMI with ATC600-C:



说明：触摸屏通过 RS485 接口连接一只 ATC600-C 实现温湿度集中显示，1 只个 ATC600-C 可接收 240 只温湿度传感器。

Note: The HMI is connected with an ATC600-C through RS485 interface to realize centralized temperature and humidity display, and one ATC600-C can receive 240 temperature and humidity sensors.

Headquarters: Acrel Co., Ltd.

Trade Company: Acrel E-Business(Shanghai)Co., Ltd.

Address: No.253 Yulv Road, Jiading District, Shanghai, China

Postcode: 201801

Manufacturer: Jiangsu Acrel Electrical Manufacturing Co., Ltd.

Address: No.5 Dongmeng Road, Dongmeng industrial Park, Nanzha Street, Jiangyin City,
Jiangsu Province, China

Mobile/WhatsApp: 0086-188 6162 8731

Web-site: www.acrel-electric.uk

E-mail: elsie.ren@email.acrel.cn

Postcode: 214405