

AIM-D100-T series DC Insulation Monitor

User Manual V1.4

Acrel co., Ltd.

DECLARATION

All rights reserved. No part of this manual may be reproduced, copied, or transmitted in any form without the written permission of our company. Violators will bear all consequences.

The Company reserves all legal rights.

The Company reserves the right to modify the specifications of the products described in this manual without prior notice. Please consult your local distributor for the latest specifications before placing an order.

Contents

1 Introduction	1
2 Model Description	1
3 Functional Characteristics	1
4 Technical Parameters	2
5 Installation and Connection	3
5.1 Shape and Size	3
5.2 Installation	3
5.3 Wiring	3
5.4 Wiring Diagram	4
5.5 Attention	5
6 Programming and Usage	5
6.1 Panel Description	5
6.2 LED Indicator Instructions	6
6.3 Buttons Operation	6
6.4 Description of Buttons Operation	6
7 Communication Instruction	9
7.1 Communication Protocol	9
7.2 Function Code Introduction	9
7.3 Register Address Table	10
7.4 Register Operation Description	12
7.5 Message Example	14
8 Application	14
8.1 Photovoltaic DC System	14
8.2 DC Panel System	15

AIM-D100-T series DC Insulation Monitor

1 Introduction



With the development of industry, many electrical equipment and plant equipment are powered by DC systems, which have ungrounded positive and negative terminals. For ungrounded (IT) distribution system, insulation resistance should be monitored to ensure the safe operation of the power supply system.

AIM-D100-T series DC insulation monitor can be applied in DC10~1000V system for on-line monitoring of DC ungrounded system positive and negative pole to ground insulation resistance, and send out warning or alarm signal when insulation resistance

is lower than the set value.

The product is based on the principle of unbalanced bridge, which avoids the problem that balanced bridge can not detect the insulation resistance when ground faults at both positive and negative poles.

The product can be applied to DC systems such as DC panels of power plants and substations, electric vehicle charging devices, UPS power supply systems, photovoltaic DC systems, energy storage systems and other DC power grids.

2 Model Description

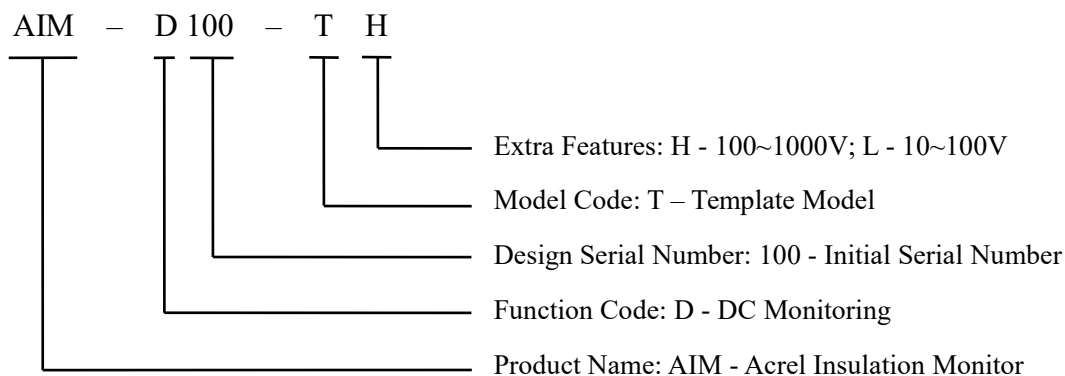

3 Functional Characteristics

- Resistance monitoring. The product can monitor the insulation resistance of the positive and negative poles of the DC system to the ground. When the insulation resistance is lower than the set warning and alarm values, it can send out warning and alarm signals.
- Voltage monitoring. The product can monitor the voltage between the positive and negative poles of the DC system and the voltage between the positive and negative poles with respect to ground.
- Over-voltage and under-voltage alarm function. The product can monitor the DC system voltage fluctuation, when there is over-voltage or under-voltage, it can issue an alarm signal in time.
- Early warning and alarm function. The product has two groups of independently adjustable set values, you can set the warning value and alarm value.

- LED indication function. The product panel has operation, communication and fault, over-voltage, under-voltage LED indicators, which can display the product status.
- LCD display function. The product adopts 128*32 dot matrix liquid crystal display, which can display parameter information.
- Relay output function. The product has 3-channel relay outputs, which can be selected as normally open or normally closed mode.
- Event record function. The product can record the time of the alarm and the type of fault, which is convenient for the staff to troubleshoot.
- Communication network function. The product has 1 RS485 interface and adopts Modbus-RTU protocol, which can be used for data interaction.
- Rail mounting. The product adopts the standard 35mm rail mounting.
- Plug-in terminals. The product adopts plug-in terminal wiring, which is convenient for wiring and installation.

4 Technical Parameters

Technical Parameter		Technical Specifications
Auxiliary power		DC 12~36V
Maximum power consumption		≤6W
Voltage monitor	Voltage range	AIM-D100-TH: DC 100~1000V; AIM-D100-TL: DC 10~100V
	Accuracy	0.5
	Overvoltage threshold	≥ Rated Voltage * 120%
	Undervoltage threshold	≤ Rated Voltage * 80%
Insulation monitoring	Insulation resistance range	1kΩ~10MΩ
	Warning and alarm range	10kΩ~10MΩ
	Accuracy	1~10kΩ: ±1k; 10k~500k: ≤3%
	System leakage capacitance	≤5μF
	Monitoring method	Cycle trigger: 5~500s delay can be set; Communication trigger: User defined, Refer 7.4
	Insulation monitoring speed	500ms/cycle; 1000ms/cycle
Internal DC impedance		<1MΩ
Alarm method		LCD, LED indicator, relay output
Alarm output		3 relay outputs, N/O or N/C can be set
Contact capacity		AC 250V 5A; DC 30V 5A
Fault Record		20 fault records
Communication		RS485 interface, Modbus-RTU protocol
Installation		DIN-rail installation

Protection level		IP30
Environment	Operating temperature	-20~+60°C
	Storage temperature	-25~+75°C
	Relative humidity	<95%, without condensation
	Altitude	< 2000m

5 Installation and Connection

5.1 Shape and Size

AIM-D100-T series DC Insulation Monitor adopts plastic casing, and its external dimensions are shown in the figure below. (Unit: mm)

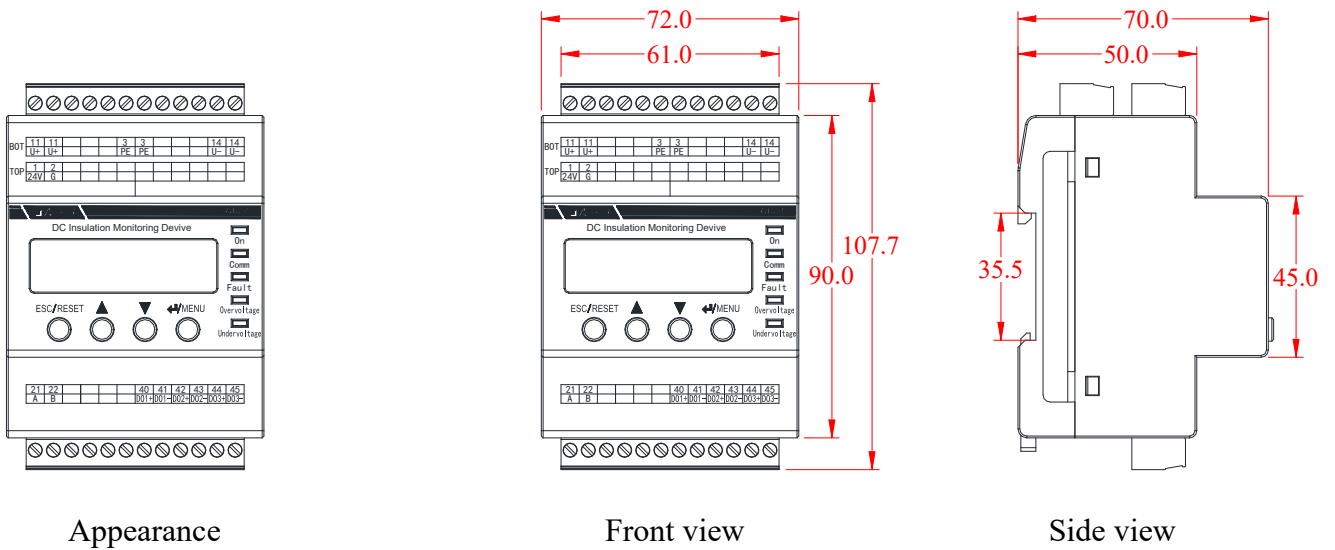

Appearance

Front view

Side view

5.2 Installation

AIM-D100-T series insulation monitor adopts rail mounting method, the installation can be completed by mounting the meter on the standard 35mm rail and fixing it with snap fasteners. As shown in the figure below:

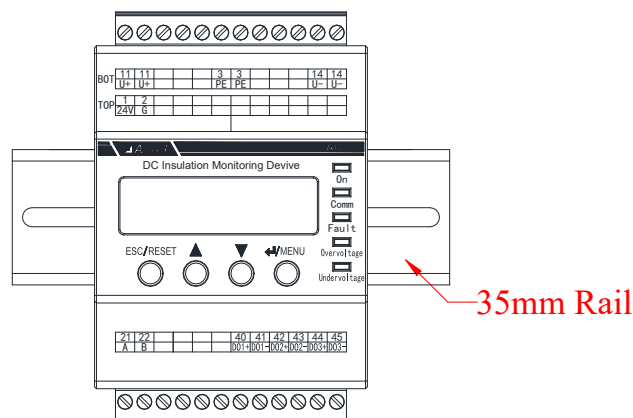

5.3 Wiring

AIM-D100-T series DC insulation monitor products have terminal blocks at the top and bottom, and the top terminal block is shown in the figure below:

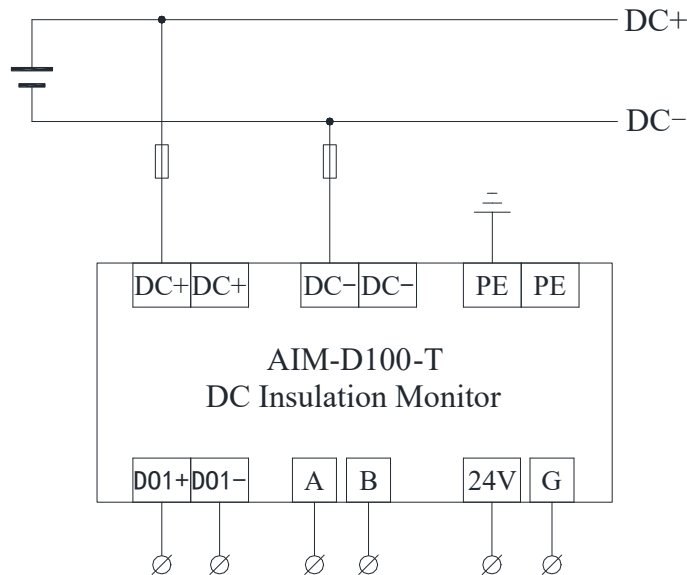

5.5 Attention

- (1) When designing and installing insulation monitors, it should be noted that only one insulation monitor can be installed in a system. If multiple insulation monitors are installed in different locations of the same system, a control strategy should be used for insulation resistance monitoring.
- (2) The insulation monitor can be installed in the distribution box, and the installation location is free of dripping water, corrosive chemical gases, and sedimentation substances.
- (3) When wiring the insulation monitor, you should strictly follow the wiring diagram. It is best to use a pin socket connector for crimping, then insert the instrument terminal and tighten the screws to avoid abnormal operation of the instrument due to poor contact.
- (4) The insulation monitor should be reliably connected to the DC system being monitored to ensure the effectiveness of insulation monitoring.
- (5) Non-professionals are strictly prohibited from opening the product casing without authorization to avoid affecting product functions.

6 Programming and Usage

6.1 Panel Description

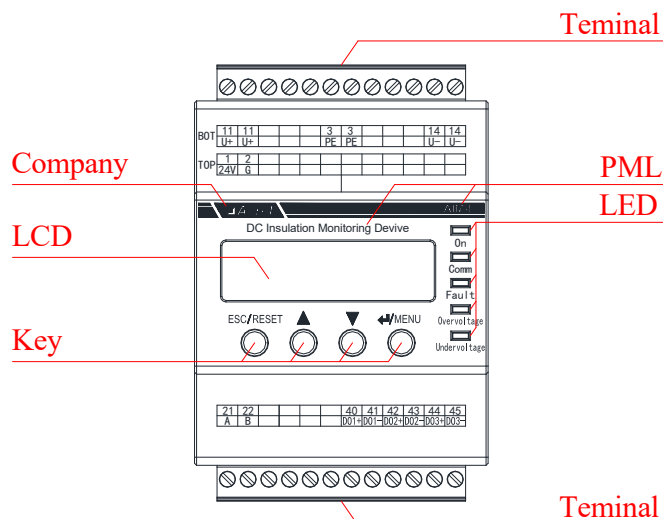

6.2 LED Indicator Instructions

Indicator	Function Description
On	When the instrument is running normally, the indicator light flashes with a flashing frequency of approximately once per second.
Comm	When there is no data communication, the indicator light is off. When there is data communication, the indicator light flashes.
Fault	The indicator light flashes when an insulation fault occurs and is always on when an insulation fault occurs.
Overvoltage	Indicator light is always on when the system voltage exceeds the nominal voltage threshold.
Undervoltage	Indicator lights up when the system voltage is below the nominal voltage threshold.

6.3 Buttons Operation

Buttons	Function
ESC / RESET	In non-programming mode, a short press is used to return to the main screen, In programming mode, a short press is used to return to the previous menu.
▲	In non-programming mode, a short press is used to switch to the previous screen, In programming mode, it is used for increasing or decreasing the value and selecting the setting item.
▼	In non-programming mode, a short press is used to switch to the next screen, In programming mode, it is used for increasing or decreasing the value and selecting the setting item.
↵ / MENU	In non-programming mode, short press to enter programming mode. In programming mode, it is used to confirm the operation.

6.4 Description of Buttons Operation

6.4.1 Button operation under the main interface

(1) Enter the running mode.

After power on, the software initialization and self-test are finished, the default mode entered is the running mode. The main interface displays system voltage "U", positive to ground voltage "U+" and negative to ground voltage "U-". Press "▼" button, you can check the system insulation resistance, positive pole to ground insulation resistance "R+", negative pole to ground insulation resistance "R-", press "▼" button, you can switch to the fault record interface. Press "▼" again to return to system voltage interface.

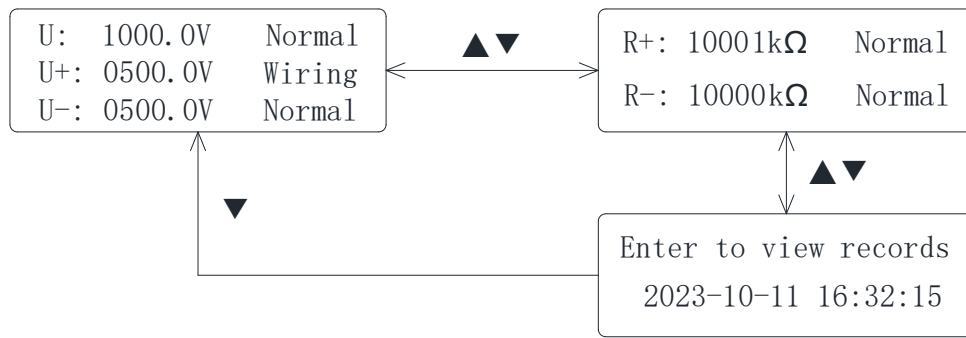

(2) Viewing Alarm Records

In the main interface, press "▼" twice to switch to the fault record interface, and press "↵ /MENU" to view specific fault records. Press "▲" and "▼" buttons to switch to page flip, query up to 20 fault records in turn, including fault type, fault value and fault time. The first fault record is the latest record, and the 20th fault record is the earliest fault record. Press "ESC/RESET" button to return to the fault record interface.

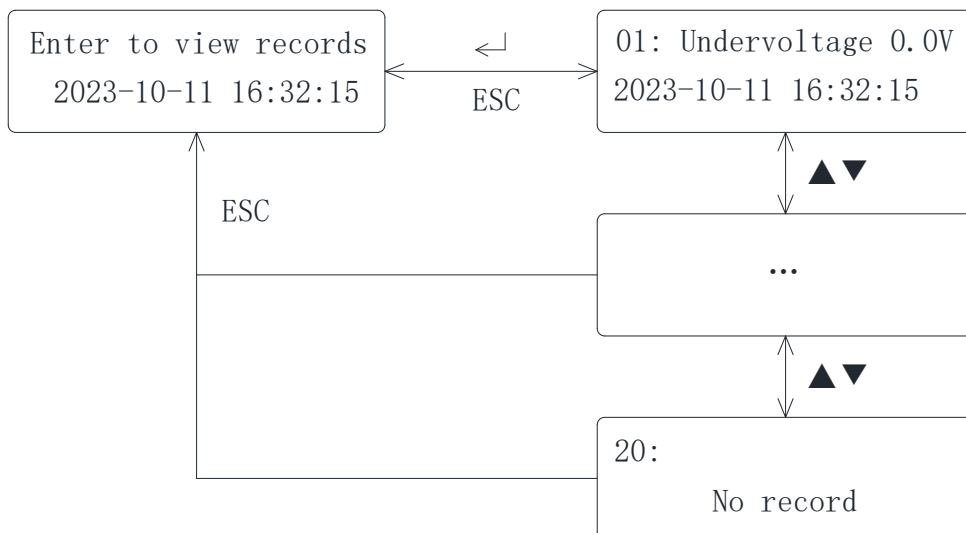

(3) Entering Programming Mode

In the main interface, press "↵ /MENU" button to enter the password input page of programming mode. Press "▲" and "▼" to enter the correct password, then press "↵ /MENU" to enter the programming mode. The default initial password of the unit is 0001.

(4) Exit Programming Mode

In programming mode, press the "ESC/RESET" button and confirm whether the set parameters are saved before exiting, then the device can exit the programming mode and enter the operation mode.

6.4.2 Related parameter settings

The details are shown in the following figure:

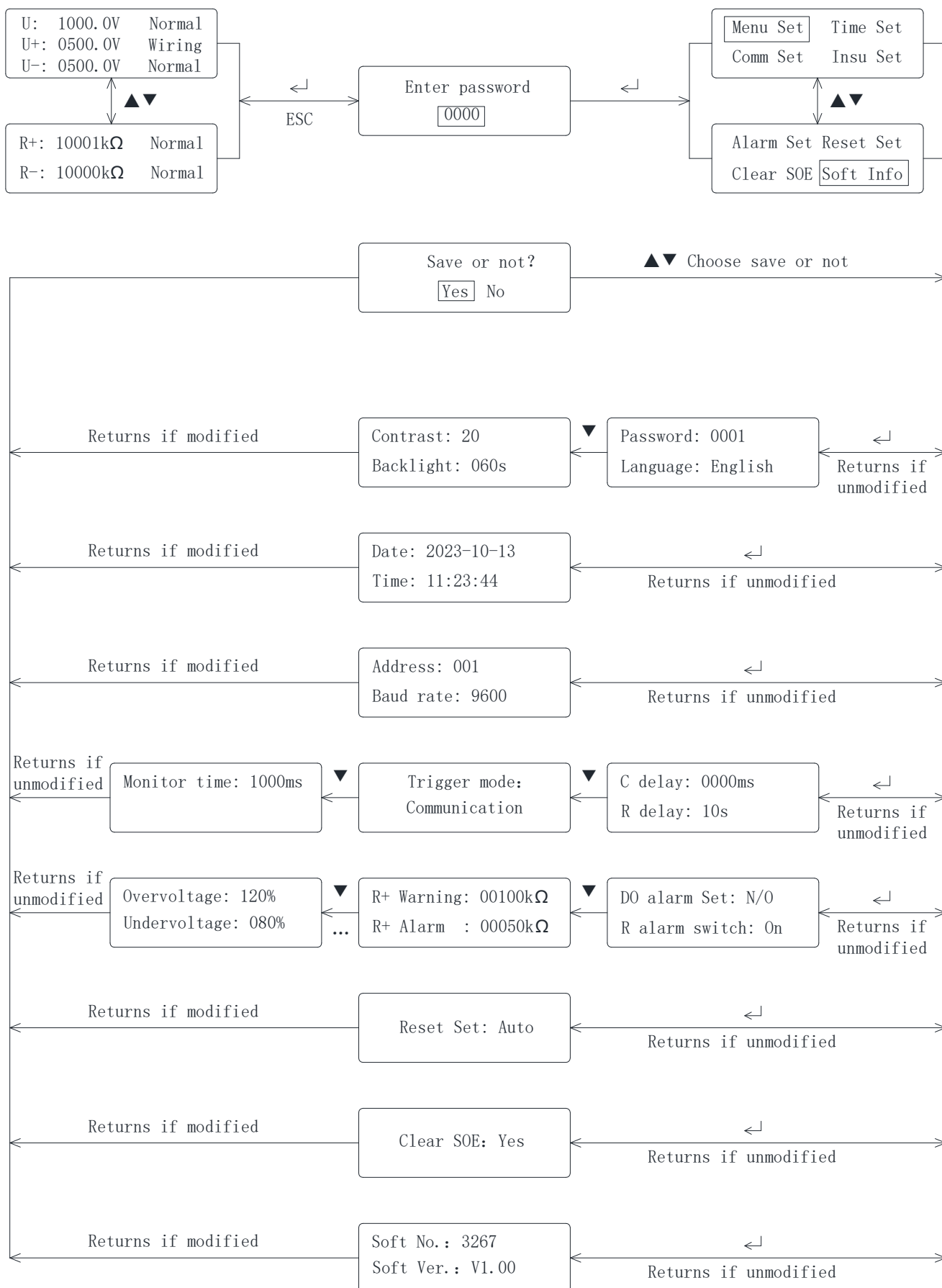

Notes: Default capacitance delay is 0000ms, monitor time is 1000ms, R delay is 5s, R+, R- warning threshold is 100kΩ, R+, R- alarm threshold is 50kΩ, Voltage alarm switch is off by default, and open after setting the rated voltage; overvoltage threshold 120%, undervoltage threshold 80%.

7 Communication Instruction

7.1 Communication Protocol

The RS485 interface of the instrument adopts the Modbus-RTU communication protocol. The protocol defines the address, function code, data, check code, etc. in detail, which is a necessary content to complete the data exchange between the host and the slave.

7.2 Function Code Introduction

7.2.1 Function code 03H or 04H: read register

This function allows users to obtain data and system parameters collected and recorded by the device. There is no limit to the number of data requested by the host at one time, but it cannot exceed the range.

The following example reads data from the 00 25H register from the slave at address 01.

Host send		Sent information	Slave return		Returned information
Address code		01H	Address code		01H
Function code		03H	Function code		03H
Starting address	High byte	00H	Byte count		02H
	Low byte	25H	Register data	High byte	1FH
Register count	High byte	00H		Low byte	68H
	Low byte	01H	CRC code	Low byte	B1H
CRC code	Low byte	95H		High byte	9AH
	High byte	C1H			

The slave returns a read result of 0x1F68, decimal 8040, indicating a system voltage of 804V.

7.2.2 Function code 06H: Write single registers

Function code 06H allows the user to change the contents of a single register without going outside the defined address range.

The following example writes 0xEFEF data to the 0034H register of the slave at address 01.

Host send		Sent information	Slave return		Returned information
Address Code		01H	Address Code		01H
Function Code		06H	Function Code		06H
Register address	High byte	00H	Register address	High byte	00H
	Low byte	34H		Low byte	34H
Data to be written	High byte	EFH	Data to be written	High byte	EFH
	Low byte	EFH		Low byte	EFH
CRC code	Low byte	C5H	CRC code	Low byte	C5H
	High byte	B8H		High byte	B8H

The host writes 0xEFEF to 00 34H to indicate that the insulation alarm switch is turned on.

7.2.3 Function Code 10H: Write Multiple Registers

Function code 10H allows the user to change the contents of multiple registers without going outside the defined address range.

The following example writes 0xFEFE, 0x0064, 0x0032 to the 0034H~0036H registers of the slave at address 01.

Host send		Sent information	Slave return		Returned information
Address Code		01H	Address Code		01H
Function Code		10H	Function code		10H
Starting address	High byte	00H	Starting address	High byte	00H
	Low byte	34H		Low byte	34H
Register count	High byte	00H	Register count	High byte	00H
	Low byte	03H		Low byte	03H
Register count		06H	CRC code	Low byte	C1H
0004H Data to be written	High byte	FEH		High byte	C6H
	Low byte	FEH			
0005H Data to be written	High byte	00H			
	Low byte	64H			
0006H Data to be written	High byte	00H			
	Low byte	32H			
CRC code	Low byte	5BH			
	High byte	AAH			

The host writes 0xFEFE, 0x0064, 0x0032 to 00 34H~00 36H to indicate that the insulation alarm switch is turned on, setting warning value of 100kΩ and alarm value of 50kΩ.

Note: The above data is for reference only. Please refer to the address table for register definitions.

7.3 Register Address Table

No.	Address	Parameter	Read /Write	Value Range	Data Types
0	00H	Password	R/W	0000~9999 (default 0001)	UINT16
1	01H	Address	R/W	1~247 (default 1)	UINT16
2	02H	Baud rate	R/W	0~3: 4800, 9600, 19200, 38400 (Unit: bps) (default 1)	UINT16
3	03H	Language	R/W	0: Chinese; 1: English (default 0)	UINT16
4	04H	LCD Contrast	R/W	10~60 (default 20)	UINT16
5	05H	LCD backlight time	R/W	0~600s 0 for constant light (default 60)	UINT16

6	06H	Year	R/W	0~99, year needs +2000	UINT16
7	07H	Mont	R/W	1~12	UINT16
8	08H	Day	R/W	1~31	UINT16
9	09H	Hour	R/W	0~23	UINT16
10	0AH	Minute	R/W	0~59	UINT16
11	0BH	Second	R/W	0~59	UINT16
12	0CH	Software number	R		UINT16
13	0DH	Software version	R		UINT16
14~31	0EH~1FH	Reserved			UINT16*18
32	20H	Fault Type	R	bit15: 1 wiring reversed; 0 is normal bit14~bit6: Reserved bit5: 1 R- warning; 0 is normal bit4: 1 R- alarm; 0 is normal bit3: 1 R+ warning; 0 is normal bit2: 1 R+ alarm; 0 is normal bit1: 1 undervoltage; 0 is normal bit0: 1 overvoltage; 0 is normal 00 18 means 0000 0000 0001 1000	UINT16
33	21H	R+	R	Unit: kΩ; Ratio is 1	UINT16
34	22H	R-	R	For example, 10000, the resistance is 10000kΩ	UINT16
35	23H	U+	R	Unit: V; Ratio is 0.1	UINT16
36	24H	U-	R	For example, 4567, the voltage is 4567*0.1=456.7V	UINT16
37	25H	U	R	Unit: V; Ratio is 0.1	UINT16
38~47	26H~2FH	Reserved			UINT16*10
48	30H	Voltage alarm switch	R/W	0xFEFE on 0xEF EF off (default is off)	UINT16
49	31H	Voltage rated value	R/W	0~1000V (default 1000)	UINT16
50	32H	Overvoltage value	R/W	100~120% (default 120)	UINT16
51	33H	Undervoltage value	R/W	80~100% (default 80)	UINT16
52	34H	Insulation alarm switch	R/W	0xFEFE is on (default is on) 0xEF EF is off	UINT16
53	35H	R+ warning value	R/W	10~10000kΩ (default 100)	UINT16
54	36H	R+ alarm value	R/W	10~10000kΩ (default 50)	UINT16
55	37H	R- warning value	R/W	10~10000kΩ (default 100)	UINT16
56	38H	R- alarm value	R/W	10~10000kΩ (default 50)	UINT16
57~62	39H~3EH	Reserved			UINT16*6

63	3FH	Insulation monitor time	R/W	0:500ms/cycle; 1:1000ms/cycle	UINT16	
64	40H	Insulation monitoring trigger mode	R/W	0x01: Cycle (default is cycle) 0x10: Communication 0x11: Cycle and Communication	UINT16	
65	41H	Capacitor delay time	R/W	0~60000ms (default 0)	UINT16	
66	42H	Resistances monitoring delay time	R/W	5~500s (default 5s)	UINT16	
67	43H	Reset mode	R/W	0: Auto; 1: Manual (default 0)	UINT16	
68	44H	DO relay mode	R/W	0: N/O; 1: N/C (default 0)	UINT16	
69	45H	Reserved			UINT16	
70	46H	Reset meter	R/W	Write 1 reset meter, invalid read	UINT16	
71	47H	Clear SOE	R/W	Write 1 clear SOE, invalid read	UINT16	
72~79	48H~4FH	Reserved			UINT16*8	
80	50H	SOE1	Fault Type	R	1: overvoltage 2: undervoltage 3: R+ insulation fault alarm 4: R+ insulation warning 5: R- insulation fault alarm 6: R- insulation warning	UINT16
81	51H		Fault Value	R	Fault resistance: unit k Ω , ratio 1; Fault voltage: unit V, ratio 0.1	UINT16
82	52H high		Year	R	Fault time-year	UINT16
	52H low		Month	R	Fault time-month	
83	53H high		Day	R	Fault time-day	UINT16
	53H low		Hour	R	Fault time-hour	
84	54H high		Minute	R	Fault time-minute	UINT16
	54H low		Second	R	Fault time-second	
85~179	55H~ B3H	SOE2~20 content	R	Format of the SOE2~20 is same as SOE1	UINT16*95	

7.4 Register Operation Description

7.4.1 Insulation Monitoring Trigger Mode

40H is the insulation monitoring trigger form, there are three main types: cycle trigger, communication trigger, cycle and communication trigger, default communication trigger.

Cycle trigger form, timed monitoring, monitoring time 500ms or 1000ms once, after monitoring update register data, after a polling delay (42H), continue to trigger monitoring. After a polling delay (42H), the monitoring will continue to be triggered. The host communication reads 20H~24H register data, and the instrument returns the latest data in the register.

Communication trigger form, polling delay (42H) is invalid, insulation monitoring in standby mode. Host communication read 20H~24H register data, the instrument triggers a monitoring, monitoring time 500ms or 1000ms once, **monitoring register data refresh and return data, monitoring time repeated reading data is invalid, not monitoring can not return data. It is recommended that the interval between two readings when communication is triggered is more than 2500ms, and the timeout time is more than 1500ms.**

Cycle and communication trigger form, the first instrument timed monitoring, monitoring process communication read 20H ~ 24H register data, the instrument triggered an insulation monitoring, monitoring time 500ms or 1000ms once, monitoring register data refresh and return data. When the next cycle is triggered, the meter automatically triggers the monitoring and refreshes the register data. This mode is used for debugging.

7.4.2 Insulation Monitoring Time

3FH is the insulation monitoring resistance time, and the insulation monitoring period can be set to 500ms or 1000ms. The accuracy of 500ms is slightly worse.

7.4.3 Insulation Monitoring Capacitor Delay Time

41H is the insulation monitoring capacitance time. When the system capacitance is $>5\mu\text{F}$, the insulation resistance monitoring has a long response time and the insulation monitoring accuracy deteriorates. You can set the insulation monitoring capacitance time to 1000ms/10 μF and increase the monitoring time to stabilize the insulation measurement and eliminate the influence of capacitance.

Monitoring time description:

The cycle trigger defines polling delay as T_d , insulation monitoring resistance time as Δt , insulation monitoring capacitance time as Δt_F ; the communication trigger defines reading interval time as T_c , and timeout as T_o . The time correspondence is shown in the following figure:

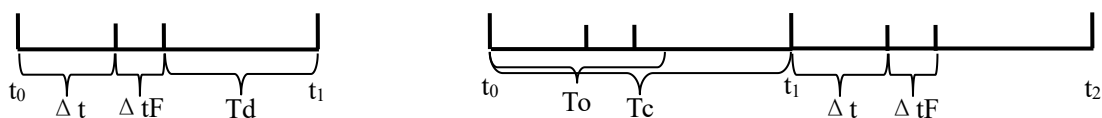

Cycle trigger

Communication trigger

7.4.4 Alarm Setting

30H~33H are voltage alarm related registers, which can set the rated voltage and issue alarm when overvoltage or undervoltage occurs in the system voltage.

34H~38H are insulation resistance related registers, which can set warning and alarm thresholds, and issue warning or alarm when insulation resistance exceeds the limit.

43H is alarm reset mode, which can be set automatically or manually. In manual mode, the meter needs to be reset manually after the fault is lifted.

44H is the relay output setting, it can be set as normally open or normally closed, and the relay status will be flipped when the alarm occurs.

7.5 Message Example

7.5.1 Read the insulation monitoring status

Host Send: 01 03 00 20 00 05 84 03

Slave Response: 01 03 0A 00 18 00 64 00 0A 11 94 01 C2 F7 A0

Data Analysis: 00 18 represents the fault type, the binary system is 0000 0000 0001 1000, the fault is positive insulation fault warning, negative insulation fault alarm; 00 64 represents the positive pole to ground insulation resistance, 100kΩ; 00 0A represents the negative pole to ground insulation resistance, 10kΩ; 11 94 represents the positive electrode to ground voltage, $4540/10=454.0V$; 01 C2 represents the negative electrode to ground voltage, $450/10=45.0V$.

7.5.2 Read the system voltage status

Host Send: 01 03 00 25 00 01 95 C1

Slave Response: 01 03 02 1F 68 B1 9A

Data Analysis: 1F 68 represents the system voltage, $8040/10=804V$.

7.5.3 Set Alarm Parameters

The alarm switch is turned on by default, the positive and negative insulation fault warning values default to 100kΩ, and the positive and negative insulation fault alarm values default to 50kΩ. No changes are required without special requirements. If you need to change, please refer to the following example.

1) Turn on the alarm switch

Host Send: 01 06 00 34 FE FE 09 E4

Slave Response: 01 06 00 34 FE FE 09 E4

2) Turn off the alarm switch

Host Send: 01 06 00 34 EF EF C5 B8

Slave Response: 01 06 00 34 EF EF C5 B8

3) Alarm threshold setting

Host send: 01 10 00 35 00 04 08 00 64 00 32 00 64 00 32 26 3E

Slave response: 01 10 00 35 00 04 D1 C4

Data analysis: 00 64 means setting the positive insulation fault alarm value to 100kΩ; 00 32 means setting the positive insulation fault alarm value to 50kΩ; 00 64 means setting the negative insulation fault alarm value to 100kΩ; 00 32 means setting the negative insulation fault alarm value to 50kΩ.

8 Application

AIM-D100-T series DC insulation monitors can be applied in PV, energy storage, DC screen, UPS and other DC systems. The following is a brief introduction to the PV DC system and DC screen system as an example.

8.1 Photovoltaic DC System

Photovoltaic power supply system converts light energy into electricity, which generally includes PV panel arrays, convergence boxes, grid-connected inverters, monitoring instruments and grid-connected

switches, etc. It can be connected to the AC grid, or provided for use by power-using equipment, or charged by energy storage modules.

The following figure in the photovoltaic system, photovoltaic module power convergence through the inverter and into the grid, the inverter with its own isolation transformer, each convergence box front-end is divided into an independent system, for the independent ungrounded DC system, should be equipped with an insulation monitor to detect the insulation of the DC bus and the branch circuit to the ground, when the occurrence of insulation damage or single-pole grounding, the instrument can be a timely alarm to alert the staff of the circuit to carry out maintenance Troubleshooting, to prevent the expansion of faults caused by short circuit. Insulation monitor on the photovoltaic DC system online monitoring, can guarantee the safety, stability, and reliability of the system.

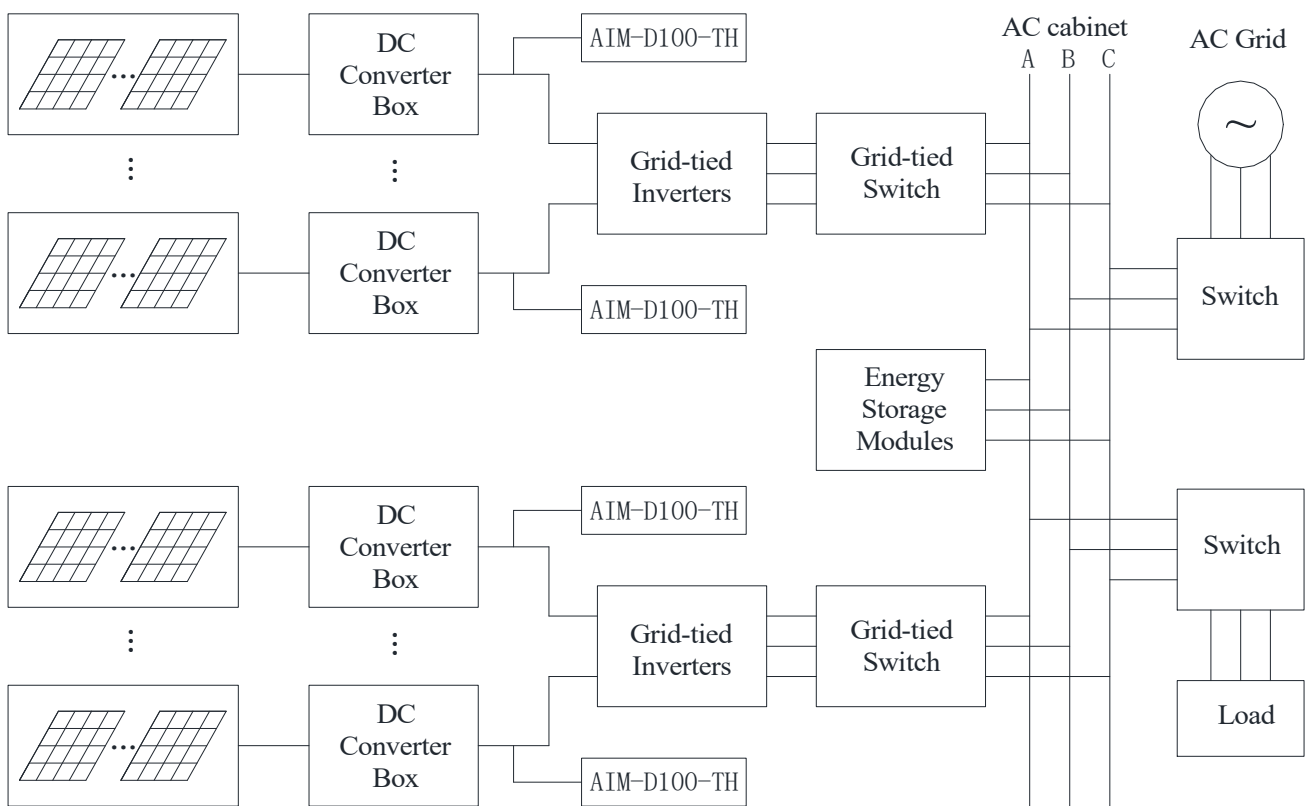

8.2 DC panel system

The monitoring and control equipment in the substation is independently powered using either DC or AC panels. For the AC screen, DC screen, the general use of ungrounded (IT) power distribution system.

The following figure DC screen distribution box system, DC screen access to AC 380V power supply, the battery module is usually in the charging state, DC screen through the 1KM +, 1KM - DC bus to provide power to the monitoring equipment, when the AC380V power supply is lost, the DC bus to continue to use the backup battery power supply, to ensure that the monitoring equipment for normal use. The instrument can monitor the insulation of DC bus and branch circuit, when any position in the DC system insulation damage or single-phase grounding occurs, the instrument sends out an alarm signal, prompting the staff to troubleshoot. The online monitoring of the DC screen system by the insulation monitor can guarantee the safety, stability, and reliability of the system.

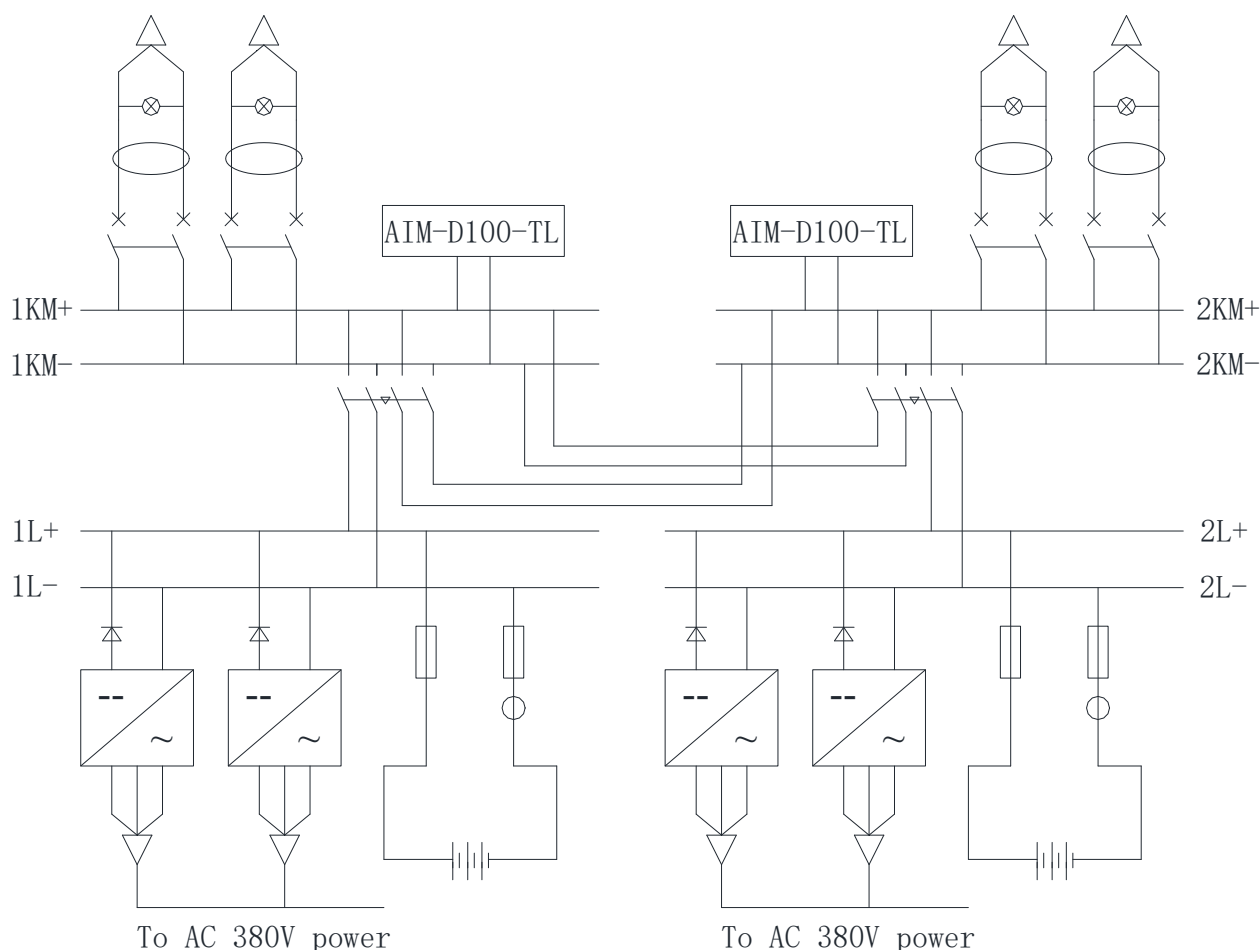

9 Fault Resolution

Make sure the wiring is correct, then turn on the meter auxiliary power. Check whether the meter is normal, for common problems, you can judge the cause and troubleshoot according to the fault phenomenon.

No.	Fault Phenomenon	Causes and Troubleshooting
1	LEDs do not light up	Check whether the meter power supply is normal. if the power supply is normal, then replace the meter.
2	Meter can't communication	(1) Check whether the communication tools are normal and whether the communication wiring A and B are correct. (2) Check the communication parameters, confirm the address, baud rate, data forma. (3) Check whether the meter is damaged or not, if the meter is damaged, then replace the met.
3	Meter can't be monitored LCD data with no change	(1) Check the wiring, whether the system voltage is normal, whether the LCD voltage is normal; (2) Check the setting, when the trigger mode is communication, external communication is needed for passive measurement, when the trigger mode is cycle, the meter measures actively according to the cycle time.
4	Meter start-up monitoring	Reverse the positive and negative poles of the meter, replace

	LCD display "wiring reversed"	the positive and negative wiring.
5	Meter start-up monitoring LED indicator flashes yellow	<p>(1) Meter monitoring is normal, the corresponding channel insulation resistance warning, remind the site to pay attention to insulation.</p> <p>(2) Insulation is good, judge the meter data is abnormal, Setting interface, modify the capacitance time to 10s, and then start monitoring to see if the data is getting bigger, and if it is not up to 10M, modify the capacitance time to 20s, and then start monitoring to see if the data is normal, and so on, the capacitance time can be set to a maximum of 60s, and the above operation can be modified remotely as well.</p> <p>Ref Msg: 01 10 00 41 00 01 02 27 10 B3 7D (10s) 01 10 00 41 00 01 02 4E 20 9D 39 (20s)</p>
6	Meter start-up monitoring LED indicator flashes red	<p>(1) Meter monitoring is normal, the corresponding channel insulation resistance alarm, to remind the field troubleshooting.</p> <p>(2) Insulation is good, to determine the meter data abnormal, the same method as above.</p>
7	Meter start-up monitoring Insulation data abnormal, LED normal, LCD display with no fault	<p>Meter insulation monitoring alarm switch off, setup interface, modify insulation monitoring alarm switch to on, also can be modified remotely.</p> <p>Ref Msg: 01 06 00 34 FE FE 09 E4</p>

Headquarters: Acrel Co., Ltd.

Trade Company: Acrel E-Business (Shanghai) Co., Ltd.

Address: No.253 Yulv Road, Jiading District, Shanghai, China

Postcode: 201801

Manufacturer: Jiangsu Acrel Electrical Manufacturing Co., Ltd.

Address: No.5 Dongmeng Road, Dongmeng industrial Park, Nanzha Street, Jiangyin City, Jiangsu
Province, China

Mobile/WhatsApp: 0086-188 6162 8731

Web-site: www.acrel-electric.uk

E-mail: elsie.ren@email.acrel.cn

Postcode: 214405