

AIM-D100-CAD Dual-channel DC Charging Pile Insulation Monitoring Device

User Manual V1.1

Declaration

Please read this instruction carefully before using this product. All pictures, logos and symbols involved are owned by Acrel Co., Ltd. All or part of the content shall not be reproduced publicly without written authorization by non-company personnel.

Please read the instructions and precautions in this operation manual carefully before using this series of products. Acrel will not be responsible for personal injury or economic loss caused by ignoring the instructions in this operation manual.

The equipment is professional electrical equipment, any related operation, need to be carried out by special electrical technicians. Acrel is not responsible for personal injury or financial loss resulting from the error of non-professional personnel.

The contents of this description will be updated and amended constantly, and it is inevitable that there will be a slight discrepancy between the physical product and the description in the product function upgrading. Please refer to the physical product purchased and obtain the latest version of the description through www.acrel-electric.com or sales channels.

Contents

1 Introduction	1
2 Model Description	1
3 Functional Characteristics	1
4 Technical Parameters	2
5 Installation and Connection	2
5.1 Shape and Size	2
5.2 Installation	3
5.3 Wiring	3
5.4 Wiring Diagram	4
5.5 Attention	5
6 Programming and Usage	5
6.1 Panel Description	5
6.2 LED Indicator Instructions	5
6.3 DIP Switch Description	6
7 Communication Instruction	6
7.1 Communication Protocol	6
7.2 Function Code Introduction	6
7.3 Register Address Table	8
7.4 Register Operation Description	10
7.5 Message Example	11
8 Application	12
9 Fault Resolution	13

AIM-D100-CAD DC Insulation Monitoring Device

1 Introduction



With the development of industry, many electrical equipment and factory equipment are powered by DC systems, and the positive and negative poles of the DC system are not grounded. For ungrounded (IT) power distribution systems, insulation resistance should be monitored to ensure the safe operation of the power supply system.

The products are mainly designed for insulation monitoring of electric vehicle double-gun charging piles in the range of

DC 100~1000V, and can also be applied to DC systems such as energy storage DC, DC panels of substations, UPS power supply systems, photovoltaic DC systems, and other DC power grids.

2 Model Description

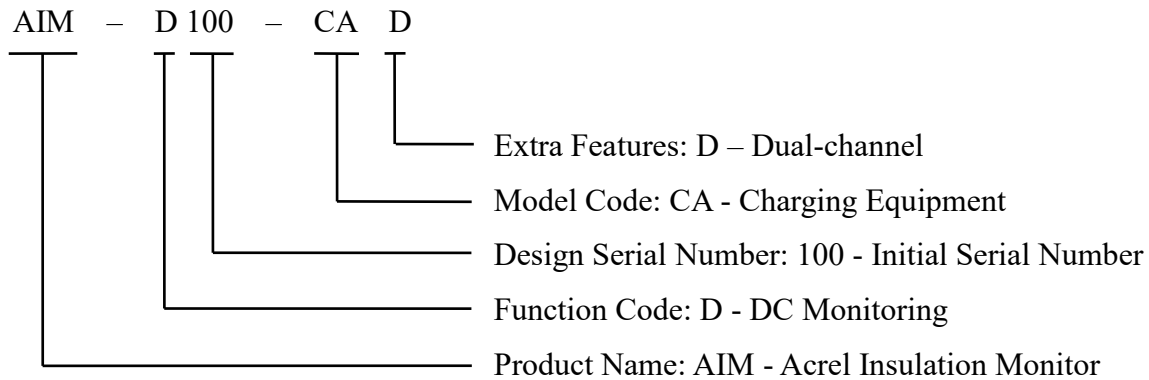

3 Functional Characteristics

- Resistance monitoring. The product can monitor the insulation resistance of the positive and negative poles of the DC system to the ground. When the insulation resistance is lower than the set warning and alarm values, it can send out warning and alarm signals.
- Voltage monitoring. The product can monitor the voltage between the positive and negative poles of the DC system and the voltage between the positive and negative poles with respect to ground. When the positive and negative poles are reversed, the meter will prompt reverse connection when reading data after working.
- Dual-channel independent monitoring. The product has two independent monitoring functions, which can separately monitor the insulation level and voltage of two DC systems.
- Dual-channel independent alarm. The product has two independent alarm functions, you can set two warning values, two alarm values.
- LED indication. The product has two RGB Led indicators, which can show the product status through different colors and frequencies.

- DIP switch setting function. The product can set the communication baud rate and the communication address through the combination of dip switches.
- Communication function. The product has RS485 interface and adopts Modbus-RTU protocol.
- Communication triggered start. The product uses the communication function to start insulation monitoring, and after starting, it monitors the insulation resistance and the positive and negative voltages to ground once, and then detaches itself from the earth after the monitoring, which does not affect the insulation level of the DC system to ground.
- Mounting options. The product adopts plastic shell, compatible with rail and wall mounting two kinds of installation methods, default rail mounting.
- Plug-in terminals. The product adopts plug-in terminal wiring, which is convenient.

4 Technical Parameters

Technical Parameter		Technical Specifications
Auxiliary power		DC 12~36V
Maximum power consumption		≤6W
Voltage monitoring	Voltage range	DC 100~1000V
	Accuracy	0.5
Insulation monitoring	Insulation resistance range	1kΩ~10MΩ
	Warning and alarm range	10kΩ~10MΩ
	Accuracy	1~10kΩ: ±1k; 10k~500k: ≤3%
	System leakage capacitance	≤5μF
	Insulation monitoring speed	500ms/cycle; 1000ms/cycle
Alarm method		RGB LED indicator
Communication		RS485 interface, Modbus-RTU protocol
Installation		Rail mounted, compatible with wall mounting
Protection level		IP30
Environment	Operating temperature	-20~+60°C
	Storage temperature	-25~+75°C
	Relative humidity	<95%, without condensation
	Altitude	<2000m

5 Installation and Connection

5.1 Shape and Size

AIM-D100-CAD dual DC charging pile insulation monitoring device adopts plastic casing, and its external dimensions are shown in the following figure. (Unit: mm)

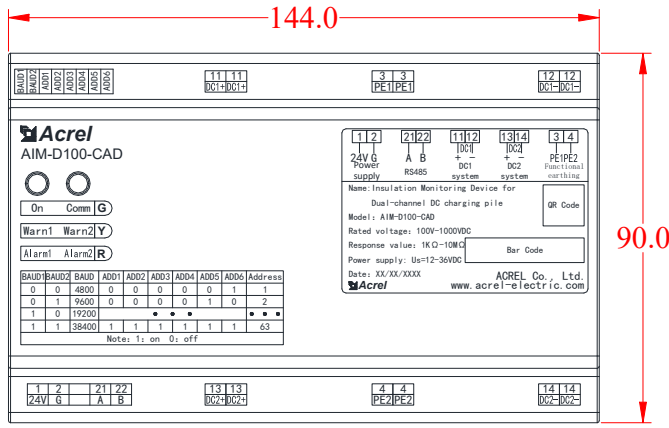

Front view

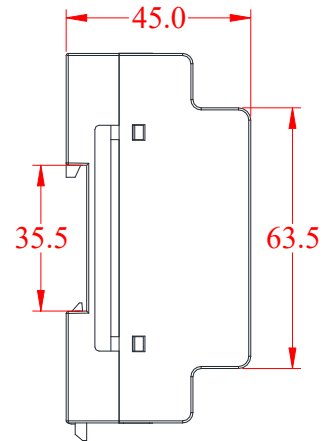

Side view

5.2 Installation

AIM-D100-CAD dual-channel DC charging pile insulation monitoring device can be installed in either rail or wall mounting.

Wall mounting: Pull out the four mounting clips on the back and use the screws to fix it on the flat surface to complete the installation.

Guide rail mounting: Fix the guide rail in the mounting position, the meter snaps into the guide rail and is fixed at both ends. The mounting dimensions are shown in the figure below. (Unit: mm)

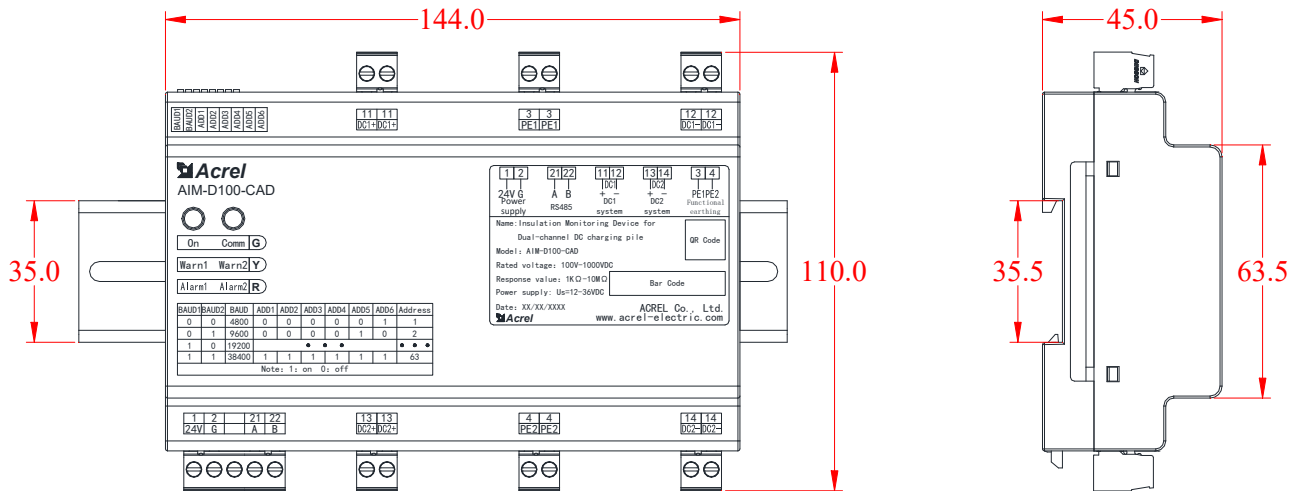

5.3 Wiring

AIM-D100-CAD dual-channel DC charging pile insulation monitoring device wiring terminals are shown below: (CH1 for channel 1, CH2 for channel 2)

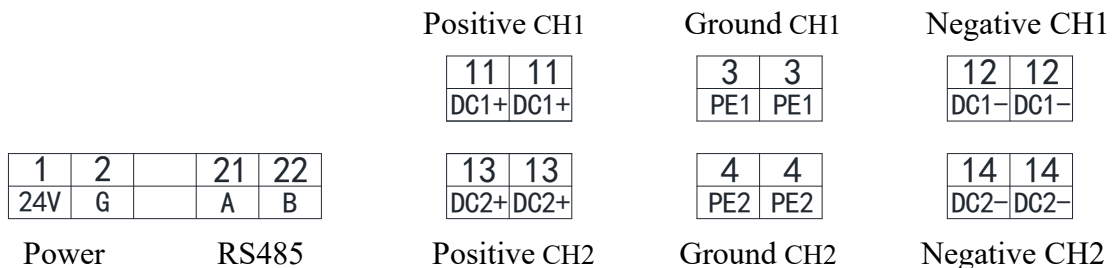

Description:

Terminal 1 and 2: Connect to DC 24V power supply;

Terminal 21 and 22: RS485 interface.

Terminals 11 and 12: No. 11 is connected to the positive pole of the DC system of CH1, and No. 12 is connected to the negative pole of the DC system of CH1. The terminals with the same serial number are connected inside the meter, and any one of them can be taken as a terminal for wiring;

Terminal 3: Connect to the field grounding row of the DC system of CH1. The terminals with the same serial number are connected inside the meter, and any one of them can be wired;

Terminals 13 and 14: No. 13 is connected to the positive pole of DC system of CH2, and No. 14 is connected to the negative pole of DC system of CH2, and the terminals with the same serial number are connected inside the meter, and either one of them can be wired;

Terminal No. 4: connected to the field grounding row of DC system of CH2, the terminals with the same serial number are connected inside the meter, and either one terminal can be wired;

Terminals No.3 and No.4 are not connected internally, and need to be connected to the grounding row of the corresponding channel when both channels are used at the same time.

Wiring Specification:

For auxiliary power supply, functional grounding, and DC system positive and negative wiring, current shunt wiring, 1.5mm² multi-core copper wires can be used. RS485 communication wiring can use 0.75~1.5mm² shielded twisted pair.

5.4 Wiring Diagram

The AIM-D100-CAD dual dc charging pile insulation monitoring device is wired as shown in the following schematic when monitoring a dual DC system:

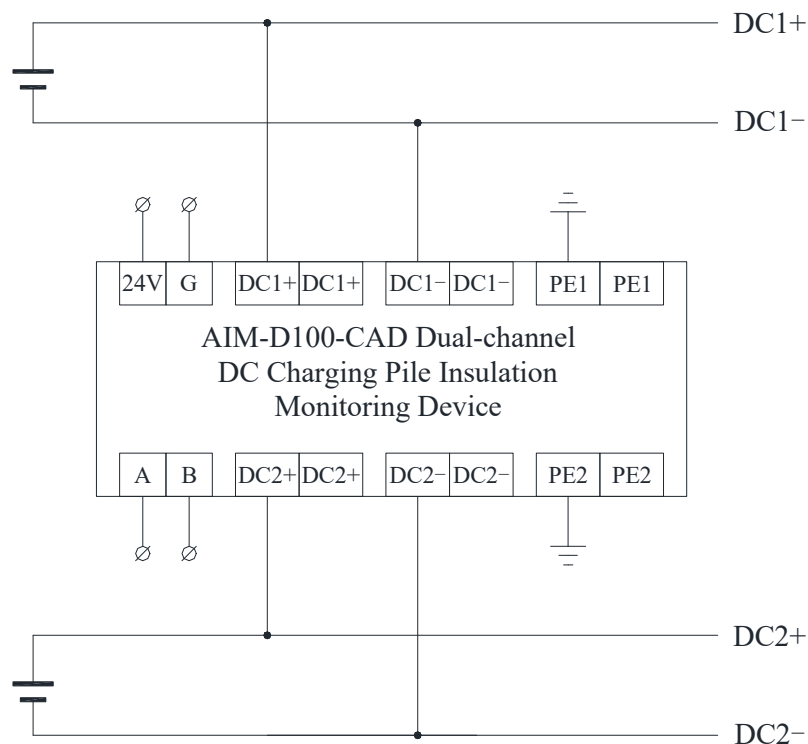

5.5 Attention

(1) When designing and installing insulation monitors, it should be noted that only one insulation monitor can be installed in a system. If multiple insulation monitors are installed in different locations of the same system, a control strategy should be used for insulation resistance monitoring.

(2) The insulation monitor can be installed in the distribution box, and the installation location is free of dripping water, corrosive chemical gases, and sedimentation substances.

(3) When wiring the insulation monitor, you should strictly follow the wiring diagram. It is best to use a pin socket connector for crimping, then insert the meter terminal and tighten the screws to avoid abnormal operation of the meter due to poor contact.

(4) The insulation monitor should be reliably connected to the DC system being monitored to ensure the effectiveness of insulation monitoring.

(5) Non-professionals are strictly prohibited from opening the product casing without authorization to avoid affecting product functions.

6 Programming and Usage

6.1 Panel Description

The AIM-D100-CAD model panel description is shown below:

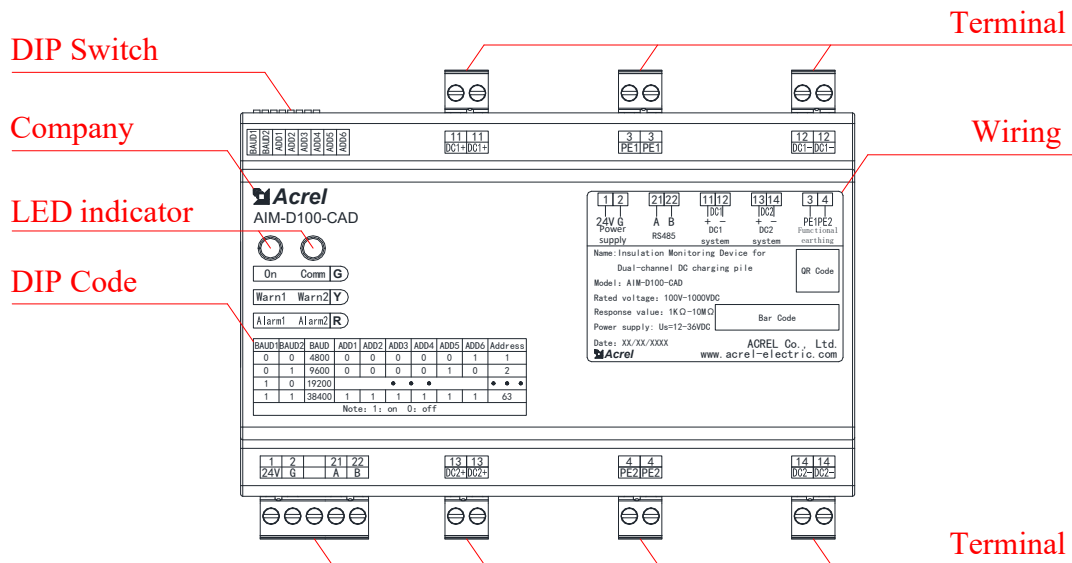

6.2 LED Indicator Instructions

Indicator	Function Description
On	<p>During normal operation of the meter, this indicator shows green and flashes;</p> <p>When the meter is in CH1 insulation warning, this indicator displays yellow and flashes;</p> <p>When the meter is in CH1 insulation alarm, this indicator displays red and flashes;</p>
Comm	<p>When there is no data communication, the indicator does not light up; when there is data communication, the indicator shows green and flashes;</p> <p>When the meter is in CH2 insulation warning, this indicator light shows yellow and flashes;</p> <p>When the meter is in CH2 insulation alarm, this indicator light shows red and flashes;</p>

6.3 DIP Switch Description

The AIM-D100-CAD dual DC charging pile insulation monitoring device is equipped with an 8-digit dipswitch at the upper left position, and the corresponding functions of the dipswitch are shown in the table below:

BAUD1	BAUD2	Baud Rate	ADD1	ADD2	ADD3	ADD4	ADD5	ADD6	Address	
0	0	4800	0	0	0	0	0	1	1	
0	1	9600	0	0	0	0	1	0	2	
1	0	19200
1	1	38400	1	1	1	1	1	1	63	
Notes: 1: on 0: off										

The combination of BAUD1 and BAUD2 dial codes: used to set the baud rate for RS485 communication. The factory default value is: 10.

The combination of ADD1~ADD6 DIP switch: used to set the address of the meter's RS485 communication. The calculation method is based on binary calculation. For example: when ADD1~ADD6 are all 1, that is, 111111 is 63, the calculation method is: $1*2^5+1*2^4+1*2^3+1*2^2+1*2^1+1*2^0=63$. When the corresponding position is 0, there is no need to calculate, such as 000001, the calculation method is: $0*2^5+0*2^4+0*2^3+0*2^2+0*2^1+1*2^0=1$, only the last digit needs to be calculated, that is $1*2^0=1$. The default value is 000001, the default is 1.

7 Communication Instruction

7.1 Communication Protocol

The RS485 interface of the meter adopts the Modbus-RTU communication protocol. The protocol defines the address, function code, data, check code, etc. in detail, which is a necessary content to complete the data exchange between the host and the slave.

7.2 Function Code Introduction

7.2.1 Function code 03H or 04H: read register

This function allows users to obtain data and system parameters collected and recorded by the device. There is no limit to the number of data requested by the host at one time, but it cannot exceed the defined address range.

The following example reads data from the 00 25H register from the slave at address 01.

Host send		Sent information	Slave return		Returned information
Address code		01H	Address code		01H
Function code		03H	Function code		03H
Starting address	High byte	00H	Byte count		02H
	Low byte	25H	Register	High byte	1FH

Register count	High byte	00H
	Low byte	01H
CRC check code	Low byte	95H
	High byte	C1H

data CRC check code	Low byte	68H
	High byte	9AH

The slave returns a read result of 0x1F68, decimal 8040, indicating a system voltage of 804V.

7.2.2 Function code 06H: Write single registers

Function code 06H allows the user to change the contents of a single register without going outside the defined address range.

The following example writes 0xEFEF data to the 0034H register of the slave at address 01.

Host send		Sent information
Address Code		01H
Function Code		06H
Register address	High byte	00H
	Low byte	34H
Data to be written	High byte	EFH
	Low byte	EFH
CRC check code	Low byte	C5H
	High byte	B8H

Slave return		Returned information
Address Code		01H
Function Code		06H
Register address	High byte	00H
	Low byte	34H
Data to be written	High byte	EFH
	Low byte	EFH
CRC check code	Low byte	C5H
	High byte	B8H

The host writes 0xEFEF to 00 34H to indicate that the insulation alarm switch is turned on.

6.2.3 Function Code 10H: Write Multiple Registers

Function code 10H allows the user to change the contents of multiple registers without going outside the defined address range.

The following example writes 0xFEFE, 0x0064, 0x0032 to the 0034H~0036H registers of the slave at address 01.

Host send		Sent information
Address Code		01H
Function Code		10H
Starting address	High byte	00H
	Low byte	34H
Register count	High byte	00H
	Low byte	03H
Register count		06H
0004H Data	High byte	FEH

Slave return		Returned information
Address Code		01H
Function code		10H
Starting address	High byte	00H
	Low byte	34H
Register count	High byte	00H
	Low byte	03H
CRC check code	Low byte	C1H
	High byte	C6H

to be written	Low byte	FEH
0005H Data	High byte	00H
to be written	Low byte	64H
0006H Data	High byte	00H
to be written	Low byte	32H
CRC	Low byte	5BH
check code	High byte	AAH

The host writes 0xFEFE, 0x0064, 0x0032 to 00 34H~00 36H to indicate that the insulation alarm switch is turned on, setting warning value of 100kΩ and alarm value of 50kΩ.

Note: The above data is for reference only. Please refer to the address table for register definitions.

7.3 Register Address Table

No.	Address	Parameter	Read /Write	Value Range	Data Type
0	00H	Reserved			UINT16
1	01H	address	R	1~63 (default 1)	UINT16
2	02H	Baud rate	R	0~3: 4800, 9600, 19200, 38400 (Unit: bps) (default 2)	UINT16
3~11	03H~0BH	Reserved			UINT16*9
12	0CH	Software number	R		UINT16
13	0DH	Software version	R		UINT16
14~31	0EH~1FH	Reserved			UINT16*18
32	20H	Fault type of CH1 (CH1 for Channel 1, the rest are the same)	R	bit15: 1 DC+ and DC- connected reversely; 0 is normal bit14~bit6: Reserved bit5: 1 negative pole insulation fault warning; 0 is normal bit4: 1 negative pole insulation fault alarm; 0 is normal bit3: 1 positive pole insulation fault warning; 0 is normal bit2: 1 positive pole insulation fault alarm; 0 is normal bit1~bit0: Reserved 00 18 means 0000 0000 0001 1000	UINT16
33	21H	Positive pole insulation resistance of CH1	R	Unit: kΩ; Ratio is 1 For example, 10000, the resistance is	UINT16
34	22H	Negative pole insulation resistance of CH1	R	10MΩ	UINT16
35	23H	Positive pole voltage to ground of CH1	R	Unit: V; Ratio is 0.1 For example, 4567, the voltage is	UINT16
36	24H	Negative pole voltage to	R	4567*0.1=456.7V	UINT16

		ground of CH1			
37	25H	System voltage of CH1	R	Unit: V; Ratio is 0.1, real-time monitoring	UINT16
38	26H	Reserved			UINT16
39~51	27H~33H	Reserved			UINT16*13
52	34H	Insulation alarm switch of CH1	R/W	0xFEFE is on (default is on) 0xEF EF is off	UINT16
53	35H	Positive pole insulation resistance warning value of CH1	R/W	10~10000kΩ (default 100)	UINT16
54	36H	Positive pole insulation resistance alarm value of CH1	R/W	10~10000kΩ (default 50)	UINT16
55	37H	Negative pole insulation resistance warning value of CH1	R/W	10~10000kΩ (default 100)	UINT16
56	38H	Negative pole insulation resistance of CH1 alarm value	R/W	10~10000kΩ (default 50)	UINT16
57~59	39H~3BH	Reserved			UINT16*3
60	3CH	Insulation monitoring speed of CH1	R/W	0: 500ms/cycle; 1: 1000ms/cycle	UINT16
61	3DH	Reserved			UINT16
62	3EH	Capacitor delay time of CH1	R/W	0~60000ms (default 0)	UINT16
63	3FH	Reserved			UINT16
64	40H	Fault type of CH2 (CH2 for Channel 2, the rest are the same)	R	bit15: 1 DC+ and DC- connected reversely; 0 is normal bit14~bit6: Reserved bit5: 1 negative pole insulation fault warning; 0 is normal bit4: 1 negative pole insulation fault alarm; 0 is normal bit3: 1 positive pole insulation fault warning; 0 is normal bit2: 1 positive pole insulation fault alarm; 0 is normal bit1~bit0: Reserved 00 18 means 0000 0000 0001 1000	UINT16
65	41H	Positive pole insulation resistance of CH2	R	Unit: kΩ; Ratio is 1	UINT16
66	42H	Negative pole insulation resistance of CH2	R	For example, 10000, the resistance is 10MΩ	UINT16
67	43H	Positive pole voltage to	R	Unit: V; Ratio is 0.1	UINT16

		ground of CH2		For example, 4567, the voltage is	
68	44H	Negative pole voltage to ground of CH2	R	4567*0.1=456.7V	UINT16
69	45H	System voltage of CH2	R	Unit: V; Ratio is 0.1, real-time monitoring	UINT16
70	46H	Reserved			UINT16
71~83	47H~53H	Reserved			UINT16*13
84	54H	Insulation alarm switch of CH2	R/W	0xFEFE is on (default is on) 0xEF EF is off	UINT16
85	55H	Positive pole insulation resistance warning value of CH2	R/W	10~10000kΩ (default 100)	UINT16
86	56H	Positive pole insulation resistance alarm value of CH2	R/W	10~10000kΩ (default 50)	UINT16
87	57H	Negative pole insulation resistance warning value of CH2	R/W	10~10000kΩ (default 100)	UINT16
88	58H	Negative pole insulation resistance of CH2 alarm value	R/W	10~10000kΩ (default 50)	UINT16
89~91	59H~5BH	Reserved			UINT16*3
92	5CH	Insulation monitoring speed of CH2	R/W	0: 500ms/cycle; 1: 1000ms/cycle	UINT16
93	5DH	Reserved			UINT16
94	5EH	Capacitor delay time of CH2	R/W	0~60000ms (default 0)	UINT16
95	5FH	Reserved			UINT16

7.4 Register Operation Description

7.4.1 Trigger Insulation Monitoring

AIM-D100-CAD dual-channel DC charging pile insulation monitoring device uses communication to start monitoring, **20H~24H (CH1) and 40H~44H (CH2) are special registers**, using 0x03H or 0x04H command to read any of them will trigger the corresponding channel to start an insulation monitoring, monitoring time 500ms or The monitoring time is 500ms or 1000ms.

When no startup command is sent, the insulation monitoring device is in standby mode and monitors the system voltage in real time. After the start command is sent, the insulation monitoring will be started, and after the monitoring is completed, it will enter the standby state and wait for the next start.

After monitoring, the register data will be refreshed and returned to the data, the repeated reading of data within the monitoring time is invalid, and the data cannot be returned without monitoring. It is recommended that the interval between two readings when communication is triggered is more than 2500ms, and the timeout time is more than 1500ms.

It is recommended to send startup monitoring command manually for a single time, and send startup monitoring command once for the corresponding channel.

7.4.2 Insulation Monitoring Speed

3CH (CH1) and 5C (CH2) are the insulation resistance monitoring time, and the insulation monitoring period can be set to 500ms or 1000ms, of which the accuracy of 500ms is slightly worse.

7.4.3 Delay Time of Insulation Monitoring Capacitor

3EH (CH1) and 5EH (CH2) are the insulation monitoring capacitance time. When the system capacitance is $>5\mu\text{F}$, the insulation resistance monitoring deteriorates the insulation monitoring accuracy due to the long response time, and the insulation monitoring capacitance time of $10,000\text{ms}/10\mu\text{F}$ can be set to increase the monitoring time in order to stabilize the insulation measurements and to eliminate the effect of capacitance.

Monitoring time description:

Insulation monitoring resistance time is Δt , insulation monitoring capacitance time is Δt_F , communication trigger defines reading interval time as T_c and timeout as T_o . The time correspondence is shown below:

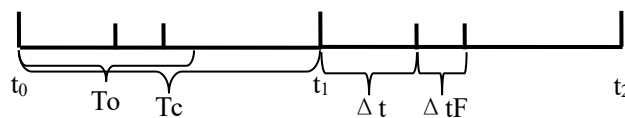

7.5 Message Example

20H~24H (CH1) and 40H~44H (CH2) registers have the same format content. After the host sends a telegram, the meter starts insulation monitoring of the corresponding channel and returns data after monitoring. The message example takes CH1 insulation monitoring as an example, CH2 slave response and data parsing refer to CH1.

7.5.1 Read the insulation monitoring status

Host Send: 01 03 00 20 00 05 84 03

Slave Response: 01 03 0A 00 18 00 64 00 0A 11 94 01 C2 F7 A0

Data Analysis: 00 18 represents the fault type, the binary system is 0000 0000 0001 1000, the fault is positive insulation fault warning, negative insulation fault alarm; 00 64 represents the positive pole to ground insulation resistance, 100kΩ; 00 0A represents the negative pole to ground insulation resistance, 10kΩ; 11 94 represents the positive electrode to ground voltage, $4540/10=454.0\text{V}$; 01 C2 represents the negative electrode to ground voltage, $450/10=45.0\text{V}$.

Host Send: 01 03 00 40 00 05 84 1D (CH2)

7.5.2 Read the system voltage status

Host Send: 01 03 00 25 00 01 95 C1

Slave Response: 01 03 02 1F 68 B1 9A

Data Analysis: 1F 68 represents the system voltage, $8040/10=804V$.

Host Send: **01 03 00 45 00 01 95 DF (CH2)**

7.5.3 Set Alarm Parameters

The alarm switch is turned on by default, the positive and negative insulation fault warning values default to $100k\Omega$, and the positive and negative insulation fault alarm values default to $50k\Omega$. No changes are required without special requirements. If you need to change, please refer to the following example.

(1) Turn on the alarm switch

Host Send: **01 06 00 34 FE FE 09 E4**

Slave Response: **01 06 00 34 FE FE 09 E4**

Host Send: **01 06 00 54 FE FE 09 FA (CH2)**

(2) Turn off the alarm switch

Host Send: **01 06 00 34 EF EF C5 B8**

Slave Response: **01 06 00 34 EF EF C5 B8**

Host Send: **01 06 00 54 EF EF C5 A6 (CH2)**

(3) Alarm threshold setting

Host send: **01 10 00 35 00 04 08 00 64 00 32 00 64 00 32 26 3E**

Slave response: **01 10 00 35 00 04 D1 C4**

Data analysis: 00 64 means setting the positive insulation fault alarm value to $100k\Omega$; 00 32 means setting the positive insulation fault alarm value to $50k\Omega$; 00 64 means setting the negative insulation fault alarm value to $100k\Omega$; 00 32 means setting the negative insulation fault alarm value to $50k\Omega$.

Host send: **01 10 00 55 00 04 08 00 64 00 32 00 64 00 32 A6 BE (CH2)**

8 Application

Electric vehicle charging device generally consists of cabinet, several AC to DC charging modules, intelligent switching unit, measuring meter, controller, contactor, charging gun and so on.



The following figure shows an example of the application of AIM-D100-CAD dual DC charging pile insulation monitoring device in an electric vehicle DC charging unit.

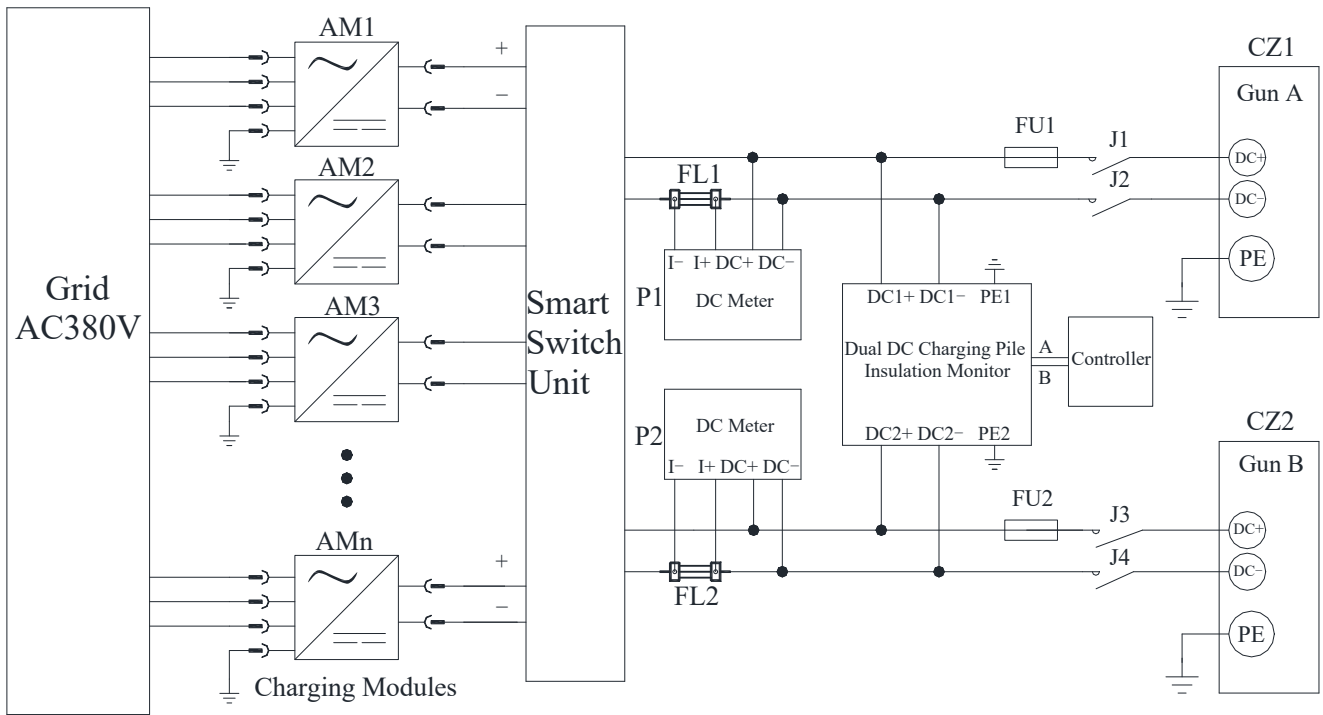

The example is a dual-gun 120kW DC charging pile. The intelligent switching unit controls the charging module, the DC meter measures the current, the insulation monitoring device measures the voltage, the insulation resistance, and the insulation monitoring is controlled by the controller. When the charging pile is in use, when charging gun A or B is used alone, the controller sends out a command to control the insulation monitor to start the corresponding channel for insulation monitoring; when charging guns A and B are used at the same time, the controller sends out a command to control the insulation monitoring device to start the dual-channel insulation monitoring. Insulation monitor returns the results, and the controller judges whether to carry out the next operation according to the results. If the insulation level does not meet the requirements, the next operation will not be carried out.

Relevant regulations describe that when $R > 500 \Omega/V$ is regarded as safe; $100 \Omega/V < R \leq 500 \Omega/V$, insulation alarm, but can still be charged normally; $R \leq 100 \Omega/V$ is regarded as an insulation fault, and charging should be stopped.

According to the calculation of the output voltage, the insulation resistance value $R > 100 \sim 375k\Omega$ is regarded as safe, and the insulation resistance value $R < 20 \sim 75k\Omega$ is regarded as insulation fault, and charging should be stopped. The safety, stability and reliability of the DC charging system is guaranteed through the coordinated work of the controller and the insulation monitor.

9 Fault Resolution

Make sure the wiring is correct, then turn on the meter auxiliary power. Check whether the meter is normal, for common problems, you can judge the cause and troubleshoot according to the fault phenomenon.

No.	Fault Phenomenon	Causes and Troubleshooting
1	LEDs do not light up	Check whether the meter power supply is normal. if the

		power supply is normal, then replace the meter.
2	Meter can't communication	<p>(1) Check whether the communication tools are normal and whether the communication wiring A and B are correct.</p> <p>(2) Check the communication parameters, confirm the address, baud rate, data forma.</p> <p>(3) Check whether the meter is damaged or not, if the meter is damaged, then replace the met.</p>
3	Meter communication start-up monitoring 20H and 40H both show 0x8000	Reverse the positive and negative poles of the meter, replace the positive and negative wiring.
4	Meter communication start-up monitoring LED indicator flashes yellow	<p>(1) Meter monitoring is normal, the corresponding channel insulation resistance warning, remind the site to pay attention to insulation.</p> <p>(2) insulation is good, judge the meter data is abnormal, 3EH (CH1) or 5EH (CH2) write 0x2710 (10s), and then start monitoring to see if the data is getting bigger, bigger than 10M, you can write 0x4E20 (20s), and then start monitoring to see if the data is normal, and so on, the capacitance time can be set to a maximum of 60s.</p> <p>Ref Msg: 01 10 00 3E 00 01 02 <u>27 10</u> B8 B2 (CH1 10s)</p> <p>01 10 00 3E 00 01 02 <u>4E 20</u> 96 F6 (CH1 20s)</p> <p>01 10 00 5E 00 01 02 <u>27 10</u> B1 12 (CH2 10s)</p> <p>01 10 00 5E 00 01 02 <u>4E 20</u> 9F 56 (CH2 20s)</p>
5	Meter communication start-up monitoring LED indicator flashes red	<p>(1) Meter monitoring is normal, the corresponding channel insulation resistance alarm, to remind the field troubleshooting.</p> <p>(2) insulation is good, to determine the meter data abnormal, the same method as above.</p>
6	Meter communication start-up monitoring Insulation data abnormal, LED normal, fault type normal	<p>Meter insulation monitoring alarm switch off, 34H (CH1) or 54H (CH2) write to 0xFEFE.</p> <p>Ref Msg: 01 06 00 34 <u>FE FE</u> 09 E4 (CH1)</p> <p>01 06 00 54 <u>FE FE</u> 09 FA (CH2)</p>

Headquarters: Acrel Co., Ltd.

Trade Company: Acrel E-Business (Shanghai) Co., Ltd.

Address: No.253 Yulv Road, Jiading District, Shanghai, China

Postcode: 201801

Manufacturer: Jiangsu Acrel Electrical Manufacturing Co., Ltd.

Address: No.5 Dongmeng Road, Dongmeng industrial Park, Nanzha Street, Jiangyin City, Jiangsu Province, China

Mobile/WhatsApp: 0086-188 6162 8731

Web-site: www.acrel-electric.uk

E-mail: elsie.ren@email.acrel.cn

Postcode: 214405