

688



AIM-D200-CAI DC Insulation Monitor

User Manual V1.2

Acrel Co., Ltd.

Declaration

Please read this instruction carefully before using this product. All pictures, logos and symbols involved are owned by Acrel Co., Ltd. All or part of the content shall not be reproduced publicly without written authorization by non-company personnel.

Please read the instructions and precautions in this operation manual carefully before using this series of products. Acrel will not be responsible for personal injury or economic loss caused by ignoring the instructions in this operation manual.

The equipment is professional electrical equipment, any related operation, need to be carried out by special electrical technicians. Acrel is not responsible for personal injury or financial loss resulting from the error of non-professional personnel.

The contents of this description will be updated and amended constantly, and it is inevitable that there will be a slight discrepancy between the physical product and the description in the product function upgrading. Please refer to the physical product purchased and obtain the latest version of the description through www.acrel-electric.com or sales channels.

Contents

1 Introduction	1
2 Model Description	1
3. Technology Features	1
4 Technical indicators	2
5 Appearance and Installation Wiring	2
5.1 Appearance and Size	2
5.2 Installation Method	3
5.3 Wiring Method	3
5.4 Wiring Diagram	4
5.5 Attention	4
6 Programming and Usage	5
6.1 Panel Description	5
6.2 LED Indication Description	5
7 Communication Instruction	5
7.1 Communication Protocol	5
7.2 Function Code Introduction	5
7.3 Register Address Table	7
7.4 Register Operation Description	8
7.5 Register Message Example	9
8 Application Examples	11
9 Fault Resolution	12

AIM-D200-CAI DC Insulation Monitor

1 Introduction



With the development of industry, many electrical equipment and factory equipment are powered by DC systems, and the positive and negative poles of the DC system are not grounded. For ungrounded (IT) power distribution systems, insulation resistance monitoring should be performed to ensure the safe operation of the power supply system .

AIM-D200-CAI DC insulation monitor can be used in 100 ~ 1000V DC systems for online monitoring of the insulation resistance of the positive and negative poles of an ungrounded DC system. When the insulation resistance is lower than the set value, it will send warning or alarm signal.

The product is based on the unbalanced bridge principle, which avoids the problem that the balanced bridge cannot detect the insulation resistance when ground fault at both the positive and negative poles.

The product is designed for insulation monitoring of electric vehicle charging piles in the range of 100~1000V , and can also be used in DC systems such as energy storage DC, DC panels in substations, UPS power supply systems, photovoltaic DC systems and other DC power grids.

2 Model Description

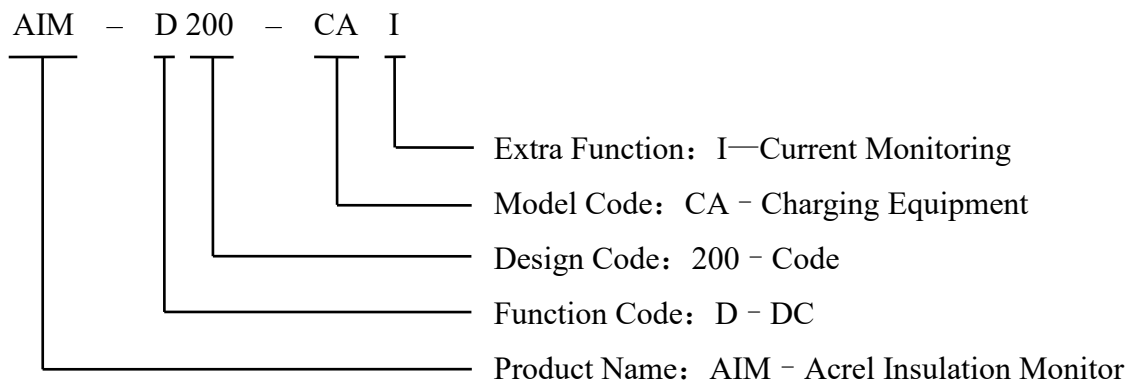

3 Technology Features

- Resistance monitoring. The product can monitor the insulation resistance of the positive and negative poles of the DC system to the ground. When the insulation resistance is lower than the set warning value and alarm value , it can issue a warning and alarm signal.
- Voltage monitoring. The product can monitor the voltage between the positive and negative poles of the DC system, and the voltage between the positive and negative poles and the ground . When the positive and negative poles are connected in reverse, the meter will prompt reverse connection when reading data after working.
- Current monitoring: The product can monitor the DC system current and select the shunt to be connected according to the rated current.

- LED indication: The product panel has operation, communication and fault LED indicators to display the product status.
- Communication function: The product has RS485 interface with Modbus-RTU protocol.
- Communication trigger start. The product uses the communication to start insulation monitoring normally. After startup, it monitors the primary insulation resistance and the positive and negative voltages to the ground. After the monitoring is completed, it is disconnected from the ground and does not affect the insulation level of the DC system to the ground.
- Guide rail installation. The product adopts plastic shell and can be installed on 35mm guide rail.
- Plug-in terminals. The product adopts plug-in terminals for wiring, which is convenient.

4 Technical Indicators

Items		Technical Parameters
Auxiliary power supply		DC 12 ~36V
Maximum power consumption		≤ 6 W
Voltage monitoring	Voltage range	DC 100 ~1000V
	Measurement accuracy	Level 2
Current monitoring	Current monitoring	Select the shunt connection according to the rated current
	Measurement accuracy	Level 0.5
Insulation monitoring	Insulation resistance range	1kΩ~ 10M Ω
	Early warning alarm range	10kΩ~10MΩ
	Measurement accuracy	1~10kΩ: ± 1k; 10k~500k: ≤ 5 %
	System leakage capacitance	≤ 5μF
	Insulation monitoring time	500ms/cycle; 1000ms/cycle
Alarm method		LED Indicator
Communication		RS485 interface; Modbus-RTU protocol
Installation		Rail installation
Protection level		IP30
Environmental parameters	Operating temperature	-20 ~ + 60 °C
	Storage temperature	-25 ~ + 75 °C
	Relative humidity	< 95%, non-condensing
	Altitude	< 2000m

5 Appearance and Installation Wiring

5.1 Appearance and Size

AIM-D200-CAI DC insulation monitor adopts plastic shell, and its dimensions are shown in the figure below. (Unit: mm)

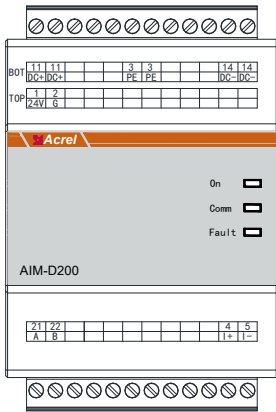

Product appearance

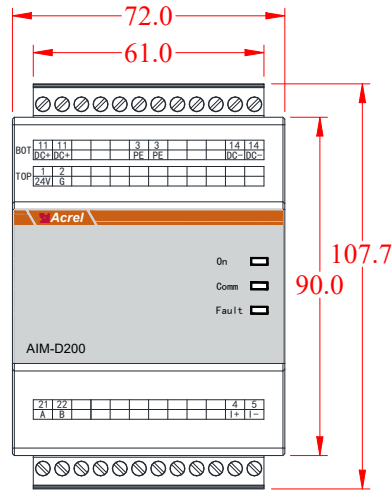

Front view

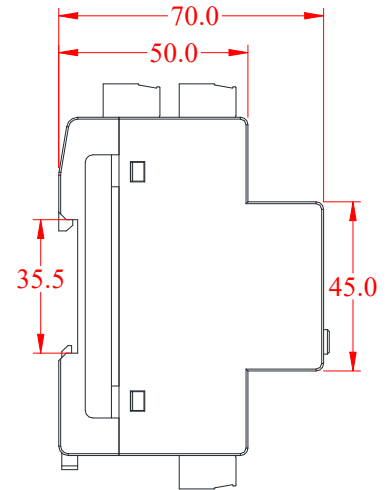

Side view

5.2 Installation Method

AIM-D200-CAI DC insulation monitor can be installed on the guide rail.

Guide rail installation: Fix the guide rail at the installation location, insert the device into the guide rail, and fix both ends. The installation dimensions are shown in the figure below. (Unit: mm)

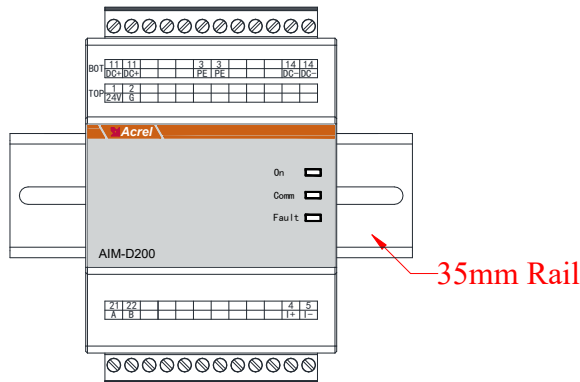

5.3 Wiring Method

The AIM - D200-CAI DC insulation monitor has wiring terminals on the top and bottom. The top wiring terminals are shown in the figure below:

	Positive		Grounding		Negative	
BOT	11	11	3	3	14	14
	DC+	DC+	PE	PE	DC-	DC-
TOP	1	2				
	24V	G				

Power Supply

The top of the meter is divided into two rows of terminals. The top row of terminals is the auxiliary power supply of the meter and needs to be connected to DC 24 V power supply, No. 1 is connected to the positive pole of the power supply, and No. 2 is connected to the negative pole of the power supply. The BOT row terminal is connected to the system wiring, No. 1 is connected to the positive pole of the DC system, No. 14 is connected to the negative pole of the DC system, and No. 3 is connected to the on-site PE grounding bar.

The lower wiring terminals are shown in the figure below:

21	22									4	5
A	B									I+	I-

RS485 Current

The wiring terminals 21 and 22 at the bottom of the device are RS 485 communication terminals. Terminal 21 is connected to terminal A and terminal 22 is connected to terminal B. They cannot be connected in reverse. Terminals 4 and 5 are current access terminals. Terminal 4 is connected to the positive pole of the shunt and terminal 5 is connected to the negative pole of the shunt.

Wiring Specifications:

Power supply, functional grounding, DC system positive and negative wiring can use 1.5 mm² multi-core copper wire. RS485 communication wiring can use 0.75~1.5mm² shielded twisted pair.

5.4 Wiring Diagram

The wiring method of the AIM-D200-CAI DC insulation monitor when monitoring the DC system is as shown in the following diagram:

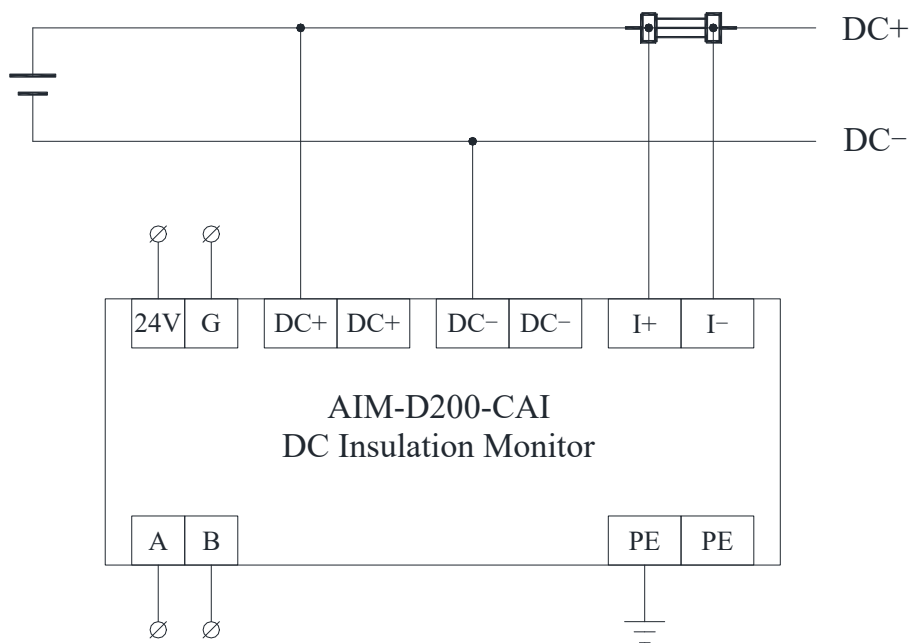

5.5 Attention

- (1) When designing and installing an insulation monitor, it should be noted that only one insulation monitor can be installed in a DC system. If multiple insulation monitors are installed in different locations in the same system, a control strategy should be used to monitor the insulation resistance.
- (2) The insulation monitor can be installed in the distribution box, and the installation location should be free of dripping water, corrosive chemical gases and sediment.
- (3) When wiring the insulation monitor, the wiring should be carried out strictly according to the wiring diagram. It is best to use a pin-type sleeve connector for crimping, then insert it into the device terminal and tighten the screws to avoid malfunction of the device due to poor contact.
- (4) The insulation monitor should be reliably connected to the monitored DC system to ensure the

effectiveness of insulation monitoring.

(5) Non-professionals are strictly prohibited from opening the product casing without authorization to avoid affecting the product function.

6 Programming and Usage

6.1 Panel Description

The AIM-D200-CAI panel description is shown in the figure below:

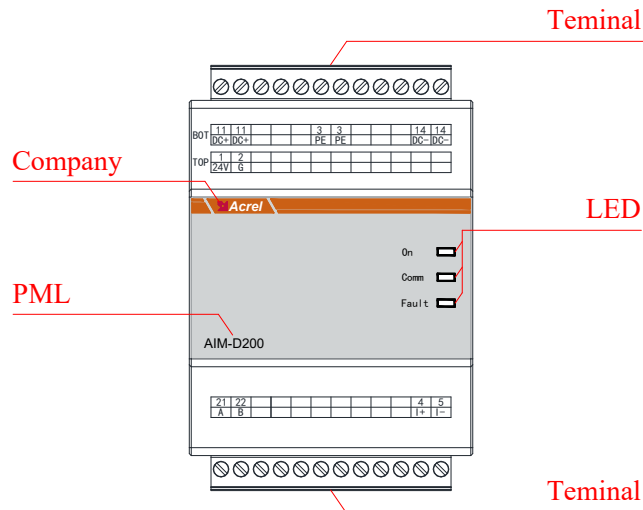

6.2 LED Indication Description

The indicator lights of AIM-D200-CAI DC insulation monitor are as follows:

Indicator Lights	Functional Description
On	When the device is operating normally, the indicator light flashes at a frequency of about once per second.
Comm	When there is no data communication, the indicator light is off, and when there is data communication, the indicator light flashes.
Fault	When the insulation fault is early warning, the indicator light flashes; when the insulation fault is alarming, the indicator light is always on

7 Communication Instruction

7.1 Communication Protocol

The RS485 interface of the instrument adopts the Modbus-RTU communication protocol. The protocol defines the address, function code, data, check code, etc. in detail, which is a necessary content to complete the data exchange between the host and the slave.

7.2 Function Code Introduction

7.2.1 Function code 03H or 04H: Read register

This function allows users to obtain data and system parameters collected and recorded by the device. There is no limit to the number of data requested by the host at one time, but it cannot exceed range.

The following example reads data from the 00 25H register from the slave at address 01.

Host send		Sent information
Address code		01H
Function code		03H
Starting address	High byte	00H
	Low byte	25H
Register count	High byte	00H
	Low byte	01H
CRC check code	Low byte	95H
	High byte	C1H

Slave return		Returned information
Address code		01H
Function code		03H
Byte count		02H
Register data	High byte	1FH
	Low byte	68H
CRC check code	Low byte	B1H
	High byte	9AH

The slave returns a read result of 0x1F68, decimal 8040, indicating a system voltage of 804V.

7.2.2 Function code 06H: Write single registers

Function code 06H allows the user to change the contents of a single register without going outside the defined address range.

The following example writes 0xEFEF data to the 0034H register of the slave at address 01.

Host send		Sent information
Address Code		01H
Function Code		06H
Register address	High byte	00H
	Low byte	34H
Data to be written	High byte	EFH
	Low byte	EFH
CRC check code	Low byte	C5H
	High byte	B8H

Slave return		Returned information
Address Code		01H
Function Code		06H
Register address	High byte	00H
	Low byte	34H
Data to be written	High byte	EFH
	Low byte	EFH
CRC check code	Low byte	C5H
	High byte	B8H

The host writes 0xEFEF to 00 34H to indicate that the insulation alarm switch is turned on.

7.2.3 Function Code 10H: Write Multiple Registers

Function code 10H allows the user to change the contents of multiple registers without going outside the defined address range.

The following example writes 0xFEFE, 0x0064, 0x0032 to the 0034H~0036H registers of the slave at address 01.

Host send		Sent information
Address Code		01H
Function Code		10H

Slave return		Returned information
Address Code		01H
Function code		10H

Starting address	High byte	00H
	Low byte	34H
Register count	High byte	00H
	Low byte	03H
Register count		06H
0004H Data to be written	High byte	FEH
	Low byte	FEH
0005H Data to be written	High byte	00H
	Low byte	64H
0006H Data to be written	High byte	00H
	Low byte	32H
CRC check code	Low byte	5BH
	High byte	AAH

Starting address	High byte	00H
	Low byte	34H
Register count	High byte	00H
	Low byte	03H
CRC check code	Low byte	C1H
	High byte	C6H

The host writes 0xFEFE, 0x0064, 0x0032 to 0034H~0036H to indicate that the insulation alarm switch is turned on, setting warning value of 100kΩ and alarm value of 50kΩ.

Note: The above data is for reference only. Please refer to the address table for register definitions.

7.3 Register Address Table

No.	Address	Parameter	Read /Write	Value range	Data Types
0	00H	Reserved			UINT16
1	01H	Address	R	1~63 (default 1)	UINT16
2	02H	Baud rate	R	0~3: 4800, 9600, 19200, 38400 (Unit: bps) (Default 1)	UINT16
3~11	03H~0BH	Reserved			UINT16*9
12	0CH	Software number	R		UINT16
13	0D	Software version	R		UINT16
14~31	0EH~1FH	Reserved			UINT16*18
32	20H	Fault type	R	bit15: 1 Positive and negative poles are connected in reversed; 0 Normal bit14~ bit6: Reserved bit5: 1 Negative insulation fault warning; 0 Normal bit4: 1 Negative insulation fault alarm; 0 normal bit3: 1 Positive insulation fault warning; 0 normal bit2: 1 Positive insulation fault alarm; 0 normal bit1~bit 0: reserved	UINT16

				For example, 00 18 means 0000 0000 0001 1000	
33	21H	Positive pole to ground insulation resistance	R	Unit: k Ω ; coefficient 1 For example, 10000 , the resistance is 10 M Ω	UINT16
34	22H	Negative pole to ground insulation resistance	R		UINT16
35	23H	Positive voltage to ground	R	Unit: V; coefficient 0.1 For example, 4567, the voltage is 4567*0.1=456.7V	UINT16
36	24H	Negative voltage to ground	R		UINT16
37	25H	System voltage	R	Unit: V; coefficient 0.1 , rated voltage	UINT16
38	26H	System current	R	Unit: A; coefficient 0.01 For example, 2500 (mV), transformation ratio 4000, current is 2500*0.01*4000=100000mA = 100A	UINT16
39~51	27H~33H	Reserved			UINT16*13
52	34H	Insulation alarm switch	R/W	0xFEFE is on (default is on) 0xEF EF Closed	UINT16
53	35H	Positive pole to ground insulation resistance warning setting value	R/W	10~10000k Ω (default 100)	UINT16
54	36H	Positive pole to ground insulation resistance alarm setting value	R/W	10~10000k Ω (default 50)	UINT16
55	37H	Negative pole to ground insulation resistance warning setting value	R/W	10~10000k Ω (default 100)	UINT16
56	38H	Negative pole to ground insulation resistance alarm setting value	R/W	10~10000k Ω (default 50)	UINT16
57~62	39H~3EH	Reserved			UINT16*6
63	3FH	Insulation resistance monitoring time	R/W	0: 500 ms/cycle 1: 1000 ms/cycle	UINT16
64	40H	Insulation monitoring trigger mode	R / W	0x01: Periodic trigger 0x10: Communication trigger (default 10)	UINT16
65	41H	Insulation monitoring capacitor time	R / W	0 ~ 60000 ms (default 0)	UINT16
66	42H	Insulation monitoring polling delay	R / W	5~500s (default 5)	UINT16

7.4 Register Operation Description

7.4.1 Trigger Insulation Monitoring

40H is the insulation monitoring trigger form, there are three main types: cycle trigger, communication

trigger, cycle and communication trigger, default cycle trigger.

Cycle trigger form, timed monitoring, monitoring time 500ms or 1000ms once, after monitoring update register data, after a polling delay (42H), continue to trigger monitoring. After a polling delay (42H), the monitoring will continue to be triggered. The host communication reads 20H~24H register data, and the instrument returns the latest data in the register.

Communication trigger form, polling delay (42H) is invalid, insulation monitoring in standby mode. Host communication read 20H~24H register data, the instrument triggers a monitoring, monitoring time 500ms or 1000ms once, **monitoring register data refresh and return data, monitoring time repeated reading data is invalid, not monitoring can not return data. It is recommended that the interval between two readings when communication is triggered is more than 2500ms, and the timeout time is more than 1500ms.**

7.4.2 Insulation Monitoring Speed

3FH is the insulation monitoring resistance time, and the insulation monitoring period can be set to 500ms or 1000ms. The accuracy of 500ms is slightly worse.

7.4.3 Delay Time of Insulation Monitoring Capacitor

41H is the insulation monitoring capacitance time. When the system capacitance is $>5\mu\text{F}$, the insulation resistance monitoring has a long response time and the insulation monitoring accuracy deteriorates. You can set the insulation monitoring capacitance time to 1000ms/10 μF and increase the monitoring time to stabilize the insulation measurement and eliminate the influence of capacitance.

The cycle trigger defines polling delay as T_d , insulation monitoring resistance time as Δt , insulation monitoring capacitance time as Δt_F ; the communication trigger defines reading interval time as T_c , and timeout as T_o . The time correspondence is shown in the following figure:

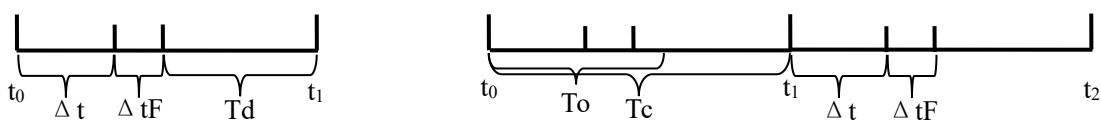

Cycle trigger

Communication trigger

7.5 Register Message Example

7.5.1 Read insulation monitoring message

Host sends: 01 03 00 20 00 05 84 03

Slave response: 01 03 0A 00 18 00 64 00 0A 11 94 01 C2 F7 A0

Data analysis: 0 0 18 indicates the fault type, which is 0 000 0000 0001 1000 in binary. The faults are positive insulation fault warning and negative insulation fault alarm. 0 0 64 indicates the insulation resistance of the positive pole to the ground, 100 k Ω . 0 0 0 A indicates the insulation resistance of the negative pole to the ground, 1 0 k Ω . 1 1 94 indicates the voltage of the positive pole to the ground, 4540/10=454.0V. 01 C2 indicates the voltage of the negative pole to the ground, 450/10=45.0V.

7.5.2 Reading system voltage message

Host sends: 01 03 00 25 00 01 95 C1

Slave response: 01 03 02 1F 68 B1 9A

Data analysis: 1F 68 represents the system voltage, $8040 / 10 = 804$ V.

7.5.3 Alarm parameter setting message

The alarm switch is turned on by default, the positive and negative insulation fault warning value is 100kΩ by default, and the positive and negative insulation fault alarm value is 50kΩ by default. No changes are required unless there is a special requirement. If changes are required, please refer to the following example.

(1) Turn on the alarm switch

Host sends: 01 06 00 34 FE FE 09 E4

Slave response: 01 06 00 34 FE FE 09 E4

(2) Turn off the alarm switch

Host sends: 01 06 00 34 EF EF C5 B8

Slave response: 01 06 00 34 EF EF C5 B8

(3) Alarm parameter settings

Host sends: 01 10 00 35 00 04 08 00 64 00 32 00 64 00 32 26 3E

Slave response: 01 10 00 35 00 04 D1 C4

Data analysis: 0 0 64 means setting the positive pole insulation fault warning value to 1 00 kΩ; 00 32 means setting the positive pole insulation fault alarm value to 50 kΩ; 0 0 64 means setting the negative pole insulation fault warning value to 1 00 kΩ; 00 32 means setting the negative pole insulation fault alarm value to 50 kΩ.

7.5.3 Changing communication parameters

Communication parameter reading and writing adopts special message of fixed frame + communication parameter.

(1) Read address and baud rate

Host sends: 41 43 52 45 4C 2D 41 49 4D 44 31 30 30 FF FF

Slave response: 41 43 52 45 4C 2D 41 49 4D 44 31 30 30 01 00

Data analysis: 41~30 are special message fixed frames, FF FF means reading communication parameters, other values are invalid; the slave responds and returns fixed frames and current communication parameters, 01 means address 01, 00 means baud rate is 4800. Baud rate correspondence: 00 corresponds to 4800, 01 corresponds to 9600, 02 corresponds to 19200, 03 corresponds to 38400.

(2) Write address and baud rate

Host sends: 41 43 52 45 4C 2D 41 49 4D 44 31 30 30 01 00

Slave response: 41 43 52 45 4C 2D 41 49 4D 44 31 30 30 01 00

Data analysis: 41~30 are special message fixed frames, 01 00 means modifying the device communication parameters to address 01, baud rate 9600, baud, and the corresponding relationship is

the same as above; the slave responds and returns the original data frame.

8 Application Examples

Electric vehicle charging device generally consists of cabinet, several AC to DC charging modules, intelligent switching unit, measuring instrument, controller, contactor, charging gun and so on.



The following figure shows the schematic of a 60kW DC charging unit.

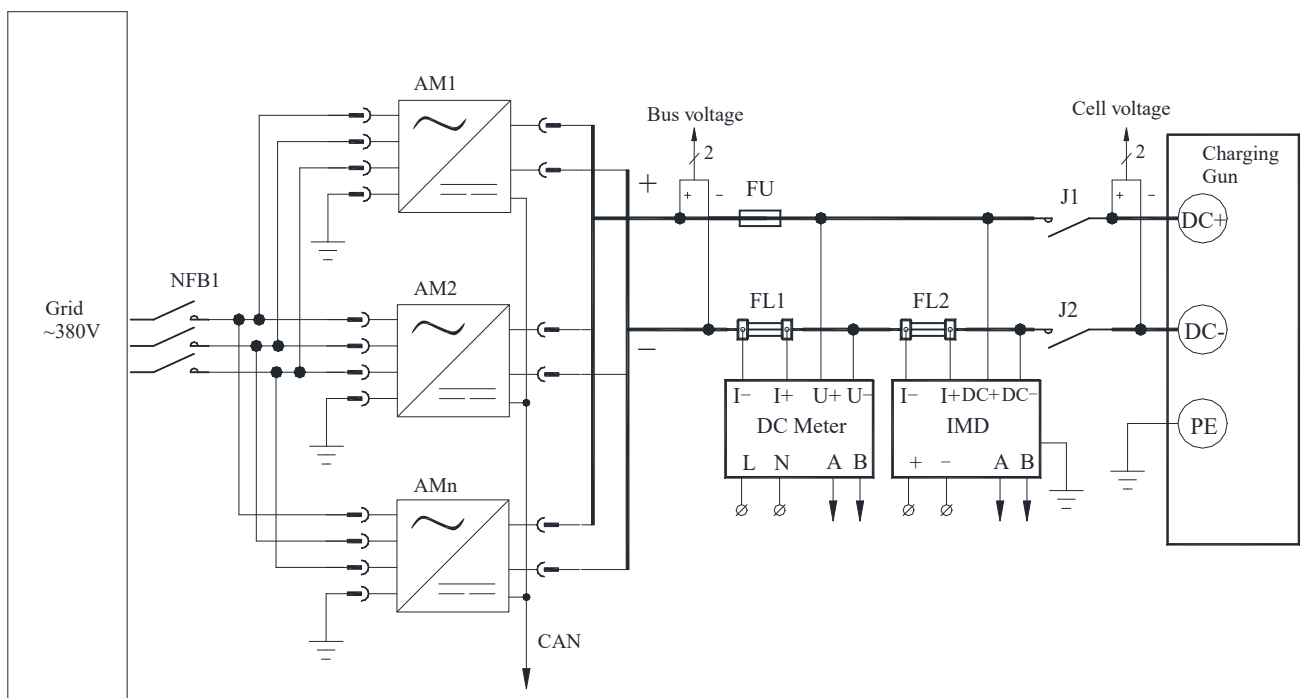

Among them, the input is three-phase AC 380V, and after the combination of multiple charging modules, the output is DC 200~750V. The DC meter measures the current, and the insulation monitor measures the voltage, current, and insulation resistance. When the charging pile is in use, the controller sends a command to control the insulation monitor to start, and it returns the results, the controller judges whether to carry out the next operation according to the results. If the insulation level does not meet the requirements, the next operation will not be carried out.

Relevant regulations describe that when $R > 500 \Omega/V$ is regarded as safe; $100 \Omega/V < R \leq 500 \Omega/V$,

insulation alarm, but can still be charged normally; $R \leq 100 \Omega/V$ is regarded as an insulation fault, and charging should be stopped.

According to the calculation of the output voltage, the insulation resistance value $R > 100 \sim 375k\Omega$ is regarded as safe, and the insulation resistance value $R < 20 \sim 75k\Omega$ is regarded as insulation fault, and charging should be stopped. The safety, stability and reliability of the DC charging system is guaranteed through the coordinated work of the controller and the insulation monitor.

9 Fault Resolution

Make sure the wiring is correct, then turn on the meter auxiliary power. Check whether the meter is normal, for common problems, you can judge the cause and troubleshoot according to the fault phenomenon.

No.	Fault Phenomenon	Causes and Troubleshooting
1	LEDs do not light up	Check whether the meter power supply is normal. if the power supply is normal, then replace the meter.
2	Meter can't communication	(1) Check whether the communication tools are normal and whether the communication wiring A and B are correct. (2) Check the communication parameters, confirm the address, baud rate, data forma. (3) Check whether the meter is damaged or not, if the meter is damaged, then replace the met.
3	Meter communication start-up monitoring 20H shows 0x8000	Reverse the positive and negative poles of the meter, replace the positive and negative wiring.
4	Meter communication start-up monitoring LED indicator flashes yellow	(1) Meter monitoring is normal, the corresponding channel insulation resistance warning, remind the site to pay attention to insulation. (2) Insulation is good, judge the meter data is abnormal, 41H write 0x2710 (10s), and then start monitoring to see if the data is getting bigger, bigger than 10M, you can write 0x4E20 (20s), and then start monitoring to see if the data is normal, and so on, the capacitance time can be set to a maximum of 60s. RefMsg: 01 10 00 41 00 01 02 27 10 B3 7D (10s) 01 10 00 41 00 01 02 4E 20 9D 39 (20s)
5	Meter communication start-up monitoring LED indicator flashes red	(1) Meter monitoring is normal, the corresponding channel insulation resistance alarm, to remind the field troubleshooting. (2) Insulation is good, to determine the meter data abnormal, the same method as above.

6	Meter communication start-up monitoring Insulation data abnormal, LED normal, fault type normal	Meter insulation monitoring alarm switch off, 34H write to 0xFEFE. RefMsg: 01 06 00 34 FE FE 09 E4
---	---	--

Headquarters: Acrel Co., Ltd.

Trade Company: Acrel E-Business (Shanghai) Co., Ltd.

Address: No.253 Yulv Road, Jiading District, Shanghai, China

Postcode: 201801

Manufacturer: Jiangsu Acrel Electrical Manufacturing Co., Ltd.

Address: No.5 Dongmeng Road, Dongmeng industrial Park, Nanzha Street, Jiangyin City, Jiangsu
Province, China

Mobile/WhatsApp: 0086-188 6162 8731

Web-site: www.acrel-electric.uk

E-mail: elsie.ren@email.acrel.cn

Postcode: 214405