

# AIM-D100-TS Series DC Insulation Monitor

User Manual V1.3

Acrel Co., Ltd.

# DECLARATION

All rights reserved. No part of this manual may be reproduced, copied, or transmitted in any form without the written permission of our company. Violators will bear all consequences.

The Company reserves all legal rights.

The Company reserves the right to modify the specifications of the products described in this manual without prior notice. Please consult your local distributor for the latest specifications before placing an order.



# Contents

1 Introduction .....	1
2 Model Description .....	1
3 Functional Characteristics .....	1
4 Technical Parameters .....	2
5 Installation and Connection .....	2
5.1 Shape and Size .....	2
5.2 Installation .....	3
5.3 Wiring Method .....	3
5.4 Wiring Diagram .....	4
5.5 Attention .....	4
6 Programming and Usage .....	5
6.1 Panel Description .....	5
6.2 LED Indicator Instructions .....	5
6.3 DIP Switch Description .....	5
7 Communication Instruction .....	6
7.1 Communication Protocol .....	6
7.2 Function Code Introduction .....	6
7.3 Register Address Table .....	8
7.4 Register Operation Description .....	9
7.5 Message Example .....	10
8 Application .....	11
9 Fault Resolution .....	11

# AIM-D100-TS series DC Insulation Monitor

## 1 Introduction



With the development of industry, many electrical equipment and factory equipment are powered by DC systems, and the positive and negative poles of the DC system are not grounded. For ungrounded (IT) power distribution systems, insulation resistance should be monitored to ensure the safe operation of the power supply system.

AIM-D100-TS series DC insulation monitor can be used in 15~1500V DC systems to monitor the

positive and negative pole-to-ground insulation resistance of ungrounded DC systems online. When the insulation resistance is lower than the set value, it will issue a pre-warning or alarm signal.

The product is mainly designed for insulation monitoring of energy storage systems in 15~1500V range. It can also be used in DC systems such as power plants, DC panels in substations, electric vehicle charging devices, UPS power supply systems, photovoltaic systems and other place.

## 2 Model Description

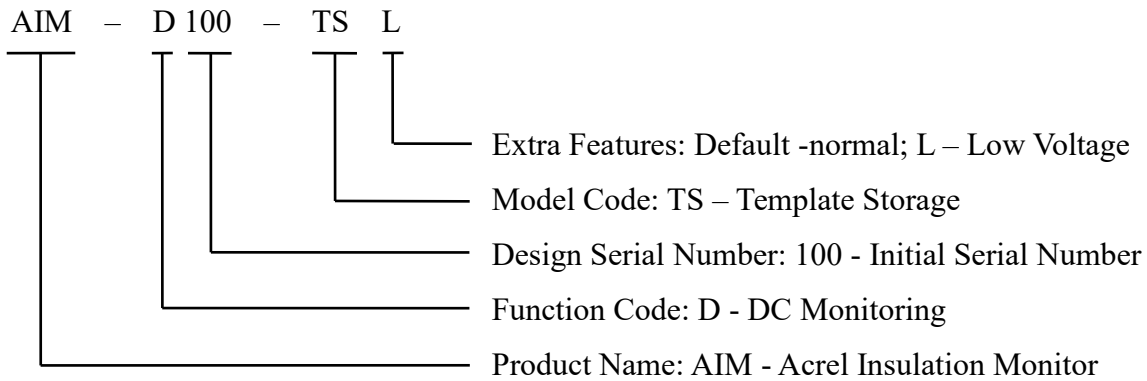

## 3 Functional Characteristics

- Resistance monitoring. The product can monitor the insulation resistance of the positive and negative poles of the DC system to the ground. When the insulation resistance is lower than the set warning and alarm values, it can send out warning and alarm signals.
- Voltage monitoring. The product can monitor the voltage between the positive and negative poles of the DC system and the voltage between the positive and negative poles with respect to ground. The measurement range is 15~1500V. When the voltage falls below or rises above the threshold, it can send out warning and alarm signals.
- LED indication. The product has 2 RGB LED indicators, which can show the product status through different colors and frequencies.
- DIP switch setting function. The product can set the communication baud rate and the

communication address through the combination of dip switches.

- Relay output function. The product has 2 relay outputs, which can be selected as normally open or normally closed mode.
- Communication. The product has RS485 interface and adopts Modbus-RTU protocol.
- Monitoring methods are selectable. The product supports both communication-triggered and cycle triggering modes, selection based on the application.
- Monitoring start/stop functionality. The product will monitor automatic in cycle triggered mode. It can be start or stop by writing to the start/stop register via communication.
- Mounting options. The product adopts plastic shell, compatible with rail and wall mounting two kinds of installation methods, default rail mounting.
- Plug-in terminals. The product adopts plug-in terminal wiring, which is convenient.

#### 4 Technical Parameters

Items		Technical Parameters	
		AIM-D100-TSL	AIM-D100-TS
Auxiliary power		DC 12~36V	
Maximum power consumption		≤3W	
Voltage monitor	Voltage range	DC 15~150V	DC 150~1500V
	Accuracy	±2%	
Insulation monitoring	Insulation resistance range	1kΩ~10MΩ	
	Warning and alarm range	10kΩ~10MΩ	
	Accuracy	1~10kΩ: ±1k; 10k~500k: ≤3%	
	System leakage capacitance	≤5μF	
	Insulation monitoring speed	500ms/cycle; 1000ms/cycle	
Alarm method		RGB LED indicator	
Alarm output		2 relay outputs, N/O or N/C can be set	
Contact capacity		AC250 5A; DC30V 5A	
Communication		RS485 interface, Modbus-RTU protocol	
Installation		Rail mounted, compatible with wall mounting	
Protection level		IP30	
Environment	Operating temperature	-20~+60°C	
	Storage temperature	-25~+75°C	
	Relative humidity	<95%, without condensation	
	Altitude	<2000m	

#### 5 Installation and Connection

##### 5.1 Shape and Size

AIM-D100-TS series DC insulation monitor adopts plastic casing, and its external dimensions are

shown in the following figure. (Unit: mm)

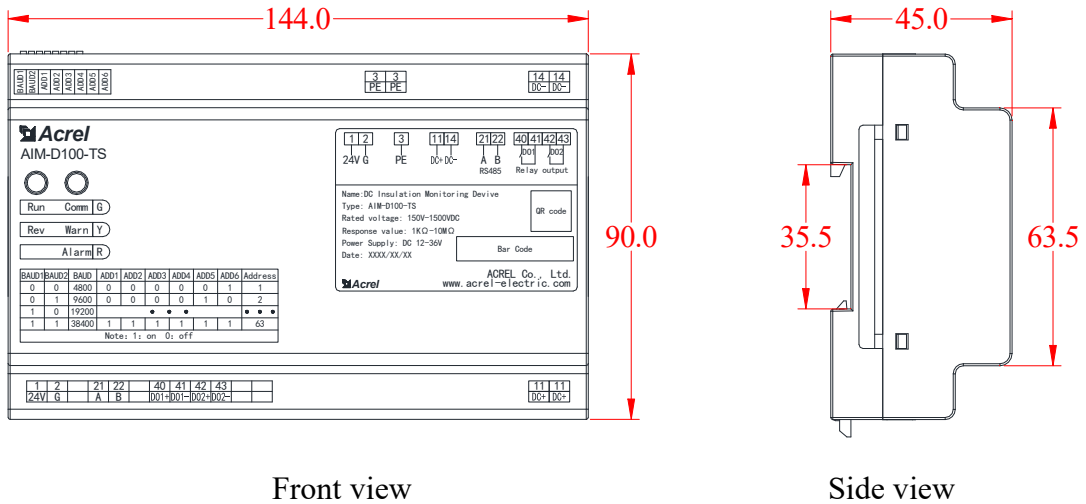

Front view

Side view

**Note: The tolerance for external dimensions is  $\pm 0.5\text{mm}$ , and tolerance for mounting dimensions is  $\pm 0.2\text{mm}$ .**

## 5.2 Installation

AIM-D100-TS series DC insulation monitor can be installed in either rail or wall mounting.

Wall mounting: Pull out the four mounting clips on the back and use the screws to fix it on the flat surface to complete the installation.

Guide rail mounting: Fix the guide rail in the mounting position, the meter snaps into the guide rail and is fixed at both ends. The mounting dimensions are shown in the figure below. (Unit: mm)

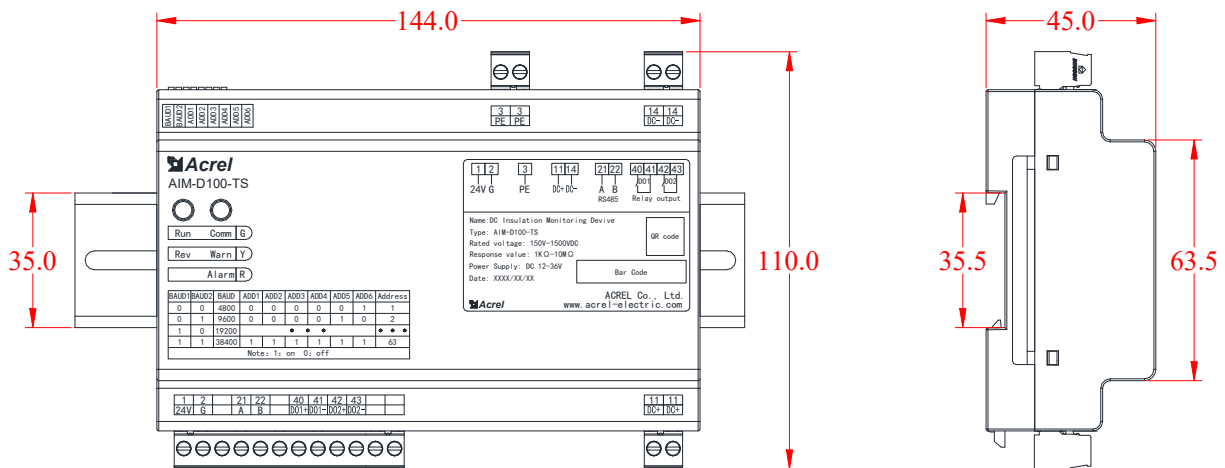

## 5.3 Wiring Method

AIM-D100-TS series DC insulation monitor wiring terminals are shown below:

Ground		Negative	
3	3	14	14
PE	PE	DC-	DC-

Power		RS485		Alarm		Warning		Positive	
1	2	21	22	40	41	42	43	11	11
24V	G	A	B	D01+	D01-	D02+	D02-	DC+	DC+

Description:

Terminal 1 and 2: Connect to DC 24V power supply, separate power supply is recommended;

Terminal 3: Connect to the on-site grounding bar, the terminals are connected inside and can be wired from either terminal.

Terminal 11: Connect to the positive pole of the DC system, the terminals are connected inside and can be wired from either terminal.

Terminal 14: Connect to the negative pole of the DC system, the terminals are connected inside and can be wired from either terminal.

Terminal 21 and 22: RS485 interface.

Terminal 40~43: two sets of relay outputs of the meter, No. 40 and 41 are DO1, No. 42 and 43 are DO2, DO2 operates when insulation warning is given, and DO1 and DO2 operate when insulation alarm is given. The relay outputs can be set in normally open or normally closed mode, and can be connected to buzzer or audible/visual alarm, the relays are passive outputs and need external power supply.

Wiring Specification:

For auxiliary power supply, ground, and DC system positive and negative wiring, 1.5mm<sup>2</sup> multi-core copper wires can be used. RS485 communication wiring can use 0.75~1.5mm<sup>2</sup> shielded twisted pair.

#### 5.4 Wiring Diagram

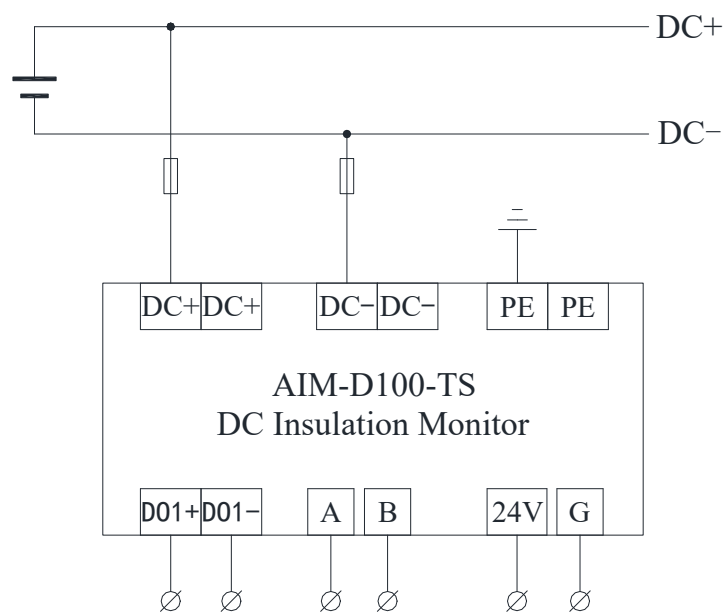

#### 5.5 Attention

(1) When designing and installing insulation monitors, it should be noted that only one insulation monitor can be installed in a system. If multiple insulation monitors are installed in different locations of the same system, a control strategy should be used for insulation resistance monitoring.

(2) The insulation monitor can be installed in the distribution box, and the installation location is free of dripping water, corrosive chemical gases, and sedimentation substances.

(3) When wiring the insulation monitor, you should strictly follow the wiring diagram. It is best to use a pin socket connector for crimping, then insert the meter terminal and tighten the screws to avoid

abnormal operation of the meter due to poor contact.

(4) The insulation monitor should be reliably connected to the DC system being monitored to ensure the effectiveness of insulation monitoring.

(5) Non-professionals are strictly prohibited from opening the product casing without authorization to avoid affecting product functions.

## 6 Programming and Usage

### 6.1 Panel Description

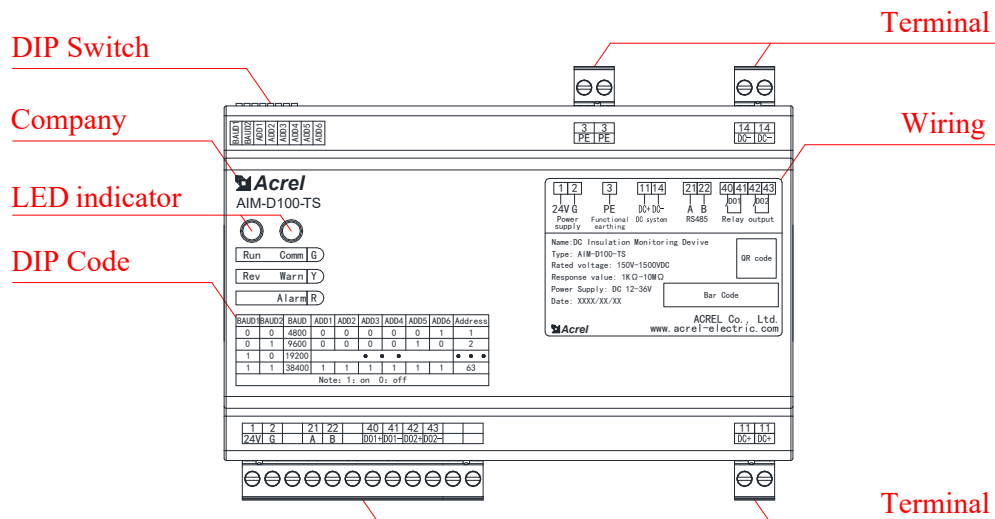

### 6.2 LED Indicator Instructions

Indicator	Function Description
Run	<p>When the meter operates normally, the indicator shows green and the indicator blinks;</p> <p>When the positive and negative poles of the meter are reversed, the indicator shows yellow and the indicator flashes;</p>
Comm	<p>When there is no data communication, the indicator does not light up; when there is data communication, the indicator shows green and blinks;</p> <p>When the meter insulation warning, the indicator light shows yellow and flashes;</p> <p>When the meter insulation alarm, this indicator light shows red and flashes.</p>

### 6.3 DIP Switch Description

There are 8-digit DIP switches on the upper terminals of the AIM-D100-TS series DC insulation monitor. The functions corresponding to each group of DIP switches are as shown in the table below:

BAUD1	BAUD2	Baud rate	ADD1	ADD2	ADD3	ADD4	ADD5	ADD6	Communication address	
0	0	4800	0	0	0	0	0	1	1	
0	1	9600	0	0	0	0	1	0	2	
1	0	19200	...							...
1	1	38400	1	1	1	1	1	1	63	

Notes: 1: on 0: off

The combination of BAUD1 and BAUD2 DIP switch: used to set the baud rate of RS485 communication. The factory default value is 10.

The combination of ADD1~ADD6 DIP switch: used to set the address of the instrument's RS485 communication. The calculation method is based on binary calculation. For example: when ADD1~ADD6 are all 1, that is, 111111 is 63, the calculation method is:  $1*2^5+1*2^4+1*2^3+1*2^2+1*2^1+1*2^0=63$ . When the corresponding position is 0, there is no need to calculate, such as 000001, the calculation method is:  $0*2^5+0*2^4+0*2^3+0*2^2+0*2^1+1*2^0=1$ , only the last digit needs to be calculated, that is  $1*2^0=1$ . The default value is 000001, the default is 1.

**The DIP switch sequence is based on the panel laser printing, with a 1 for the panel side and a 0 for the mounting side.**

## 7 Communication Instruction

### 7.1 Communication Protocol

The RS485 interface of the instrument adopts the Modbus-RTU communication protocol. The protocol defines the address, function code, data, check code, etc. in detail, which is a necessary content to complete the data exchange between the host and the slave.

### 7.2 Function Code Introduction

#### 7.2.1 Function code 03H or 04H: Read register

This function allows users to obtain data and system parameters collected and recorded by the device. There is no limit to the number of data requested by the host at one time, but it cannot exceed range.

The following example reads data from the 00 25H register from the slave at address 01.

Host send		Sent information	Slave return		Returned information
Address code		01H	Address code		01H
Function code		03H	Function code		03H
Starting address	High byte	00H	Byte count		02H
	Low byte	25H	Register data	High byte	1FH
Register count	High byte	00H		Low byte	68H
	Low byte	01H	CRC check code	Low byte	B1H
CRC check code	Low byte	95H		High byte	9AH
	High byte	C1H			

The slave returns a read result of 0x1F68, decimal 8040, indicating a system voltage of 804V.

#### 7.2.2 Function code 06H: Write single registers

Function code 06H allows the user to change the contents of a single register without going outside the defined address range.

The following example writes 0xEF EF data to the 0034H register of the slave at address 01.

Host send		Sent information
Address Code		01H
Function Code		06H
Register address	High byte	00H
	Low byte	34H
Data to be written	High byte	EFH
	Low byte	EFH
CRC check code	Low byte	C5H
	High byte	B8H

Slave return		Returned information
Address Code		01H
Function Code		06H
Register address	High byte	00H
	Low byte	34H
Data to be written	High byte	EFH
	Low byte	EFH
CRC check code	Low byte	C5H
	High byte	B8H

The host writes 0xEFEF to 00 34H to indicate that the insulation alarm switch is turned on.

### 7.2.3 Function Code 10H: Write Multiple Registers

Function code 10H allows the user to change the contents of multiple registers without going outside the defined address range.

The following example writes 0xFEFE, 0x0064, 0x0032 to the 0034H~0036H registers of the slave at address 01.

Host send		Sent information
Address Code		01H
Function Code		10H
Starting address	High byte	00H
	Low byte	34H
Register count	High byte	00H
	Low byte	03H
Register count		06H
0004H Data to be written	High byte	FEH
	Low byte	FEH
0005H Data to be written	High byte	00H
	Low byte	64H
0006H Data to be written	High byte	00H
	Low byte	32H
CRC check code	Low byte	5BH
	High byte	AAH

Slave return		Returned information
Address Code		01H
Function code		10H
Starting address	High byte	00H
	Low byte	34H
Register count	High byte	00H
	Low byte	03H
CRC check code	Low byte	C1H
	High byte	C6H

The host writes 0xFEFE, 0x0064, 0x0032 to 0034H~0036H to indicate that the insulation alarm switch is turned on, setting warning value of 100kΩ and alarm value of 50kΩ.

**Note: The above data is for reference only. Please refer to the address table for register definitions.**

### 7.3 Register Address Table

No.	Address	Parameter	Read /Write	Value range	Data Types
0	00H	Reserved			UINT16
1	01H	Communication address	R	1~63 (default 1)	UINT16
2	02H	Baud rate	R	0~3: 4800, 9600, 19200, 38400 (Unit: bps) (default 1)	UINT16
3~11	03H~ 0BH	Reserved			UINT16 *9
12	0CH	Software number	R		UINT16
13	0DH	Software version	R		UINT16
14~31	0EH~ 1FH	Reserved			UINT16 *18
32	20H	Fault type	R	bit15: 1 DC+ and DC- connected reversely; 0 is normal bit14~bit6: Reserved bit5: 1 negative pole insulation fault warning; 0 is normal bit4: 1 negative pole insulation fault alarm; 0 is normal bit3: 1 positive pole insulation fault warning; 0 is normal bit2: 1 positive pole insulation fault alarm; 0 is normal bit1~bit0: Reserved 00 18 means 0000 0000 0001 1000	UINT16
33	21H	Positive pole insulation resistance	R	Unit: kΩ; Ratio is 1 For example, 10000, the resistance is	UINT16
34	22H	Negative pole insulation resistance	R	10MΩ	UINT16
35	23H	Positive pole voltage to ground	R	Unit: V; Ratio is 0.1 For example, 4567, the voltage is	UINT16
36	24H	Negative pole voltage to ground	R	4567*0.1=456.7V	UINT16
37	25H	System voltage	R	Unit: V; Ratio is 0.1	UINT16
38	26H	Reserved	R		UINT16
39~51	27H~ 33H	Reserved			UINT16 *13
52	34H	Insulation alarm switch	R/W	0xFEFE is on (default is on) 0xEF EF is off	UINT16
53	35H	Positive pole insulation resistance warning value	R/W	10~10000kΩ (default 100)	UINT16
54	36H	Positive pole insulation resistance alarm value	R/W	10~10000kΩ (default 50)	UINT16

55	37H	Negative pole insulation resistance warning value	R/W	10~10000kΩ (default 100)	UINT16
56	38H	Negative pole insulation resistance alarm value	R/W	10~10000kΩ (default 50)	UINT16
57~60	39H~3CH	Reserved			UINT16 *4
61	3DH	Cycle mode switch status	R	0xFEFE: ON 0xEFEF: OFF	UINT16
62	3EH	Cycle mode switch	R/W	0xFEFE: ON (default) 0xEFEF: OFF (3DH~3EH is valid just in cycle mode)	UINT16
63	3FH	Insulation monitor speed	R/W	0:500ms/cycle; 1:1000ms/cycle	UINT16
64	40H	Insulation monitor trigger mode	R/W	0x01: Cycle; 0x10: Communication (default 10)	UINT16
65	41H	Capacitor delay time	R/W	0~60000ms (default 0)	UINT16
66	42H	Resistances monitor delay time	R/W	5~500s (default 5s)	UINT16
67	43H	Reserved			UINT16
68	44H	Relay mode	R/W	0: N/O 1: N/C (Default: 0)	UINT16

## 7.4 Register Operation Description

### 7.4.1 Insulation Monitoring Trigger Mode

40H is the insulation monitoring trigger form, there are three main types: cycle trigger, communication trigger, cycle and communication trigger, default cycle trigger.

Cycle trigger form, timed monitoring, monitoring time 500ms or 1000ms once, after monitoring update register data, after a polling delay (42H), continue to trigger monitoring. After a polling delay (42H), the monitoring will continue to be triggered. The host communication reads 20H~24H register data, and the instrument returns the latest data in the register.

Communication trigger form, polling delay (42H) is invalid, insulation monitoring in standby mode. Host communication read 20H~24H register data, the instrument triggers a monitoring, monitoring time 500ms or 1000ms once, **monitoring register data refresh and return data, monitoring time repeated reading data is invalid, not monitoring can not return data. It is recommended that the interval between two readings when communication is triggered is more than 2500ms, and the timeout time is more than 1500ms.**

### 7.4.2 Insulation Monitoring Speed

3FH is the insulation monitoring resistance time, and the insulation monitoring period can be set to 500ms or 1000ms. The accuracy of 500ms is slightly worse.

### 7.4.3 Delay Time of Insulation Monitoring Capacitor

41H is the insulation monitoring capacitance time. When the system capacitance is  $>5\mu\text{F}$ , the insulation resistance monitoring has a long response time and the insulation monitoring accuracy deteriorates. You can set the insulation monitoring capacitance time to 1000ms/10 $\mu\text{F}$  and increase the

monitoring time to stabilize the insulation measurement and eliminate the influence of capacitance.

The cycle trigger defines polling delay as  $T_d$ , insulation monitoring resistance time as  $\Delta t$ , insulation monitoring capacitance time as  $\Delta t_F$ ; the communication trigger defines reading interval time as  $T_c$ , and timeout as  $T_o$ . The time correspondence is shown in the following figure:

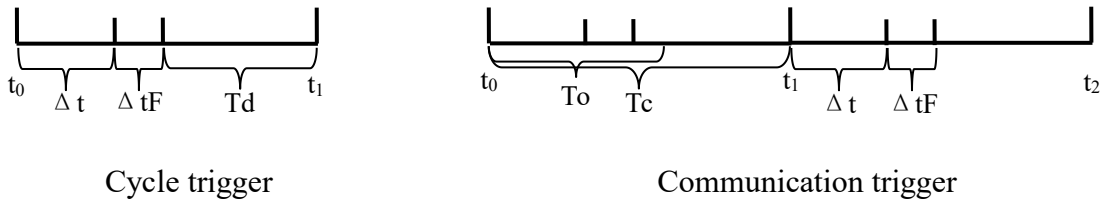

Cycle trigger

Communication trigger

## 7.5 Message Example

### 7.5.1 Read the insulation monitoring status

Host Send: `01 03 00 20 00 05 84 03`

Slave Response: `01 03 0A 00 18 00 64 00 0A 11 94 01 C2 F7 A0`

Data Analysis: 00 18 represents the fault type, the binary system is 0000 0000 0001 1000, the fault is positive insulation fault warning, negative insulation fault alarm; 00 64 represents the positive pole to ground insulation resistance, 100k $\Omega$ ; 00 0A represents the negative pole to ground insulation resistance, 10k $\Omega$ ; 11 94 represents the positive electrode to ground voltage, 4540/10=454.0V; 01 C2 represents the negative electrode to ground voltage, 450/10=45.0V.

### 7.5.2 Read the system voltage status

Host Send: `01 03 00 25 00 01 95 C1`

Slave Response: `01 03 02 1F 68 B1 9A`

Data Analysis: 1F 68 represents the system voltage, 8040/10=804V.

### 7.5.3 Set Alarm Parameters

The alarm switch is turned on by default, the positive and negative insulation fault warning values default to 100k $\Omega$ , and the positive and negative insulation fault alarm values default to 50k $\Omega$ . No changes are required without special requirements. If you need to change, please refer to the following example.

(1) Turn on the alarm switch

Host Send: `01 06 00 34 FE FE 09 E4`

Slave Response: `01 06 00 34 FE FE 09 E4`

(2) Turn off the alarm switch

Host Send: `01 06 00 34 EF EF C5 B8`

Slave Response: `01 06 00 34 EF EF C5 B8`

(3) Alarm threshold setting

Host send: `01 10 00 35 00 04 08 00 64 00 32 00 64 00 32 26 3E`

Slave response: `01 10 00 35 00 04 D1 C4`

Data analysis: 00 64 means setting the positive insulation fault alarm value to 100k $\Omega$ ; 00 32 means setting the positive insulation fault alarm value to 50k $\Omega$ ; 00 64 means setting the negative insulation

fault alarm value to 100kΩ; 00 32 means setting the negative insulation fault alarm value to 50kΩ.

## 8 Application

The principle of mounting insulation monitors is to use one insulation monitor for the same stand-alone system; when more than one insulation monitor is used, they can interfere with each other and affect the monitoring. Insulation monitors can be used in energy storage systems to monitor the insulation of individual battery clusters as well as the overall insulation. In the energy storage system, the main control module is used to control the working status of each insulation monitor, and the time-sharing control strategy is adopted to ensure that only one insulation monitor is in working status at the same time, and that the insulation monitors do not interfere with each other, and at the same time to ensure that the energy storage system can carry out insulation monitoring at all times, so as to guarantee the safety, stability and reliability of the system.

The following figure shows the application example of AIM-D100-TS DC insulation monitor in energy storage system.

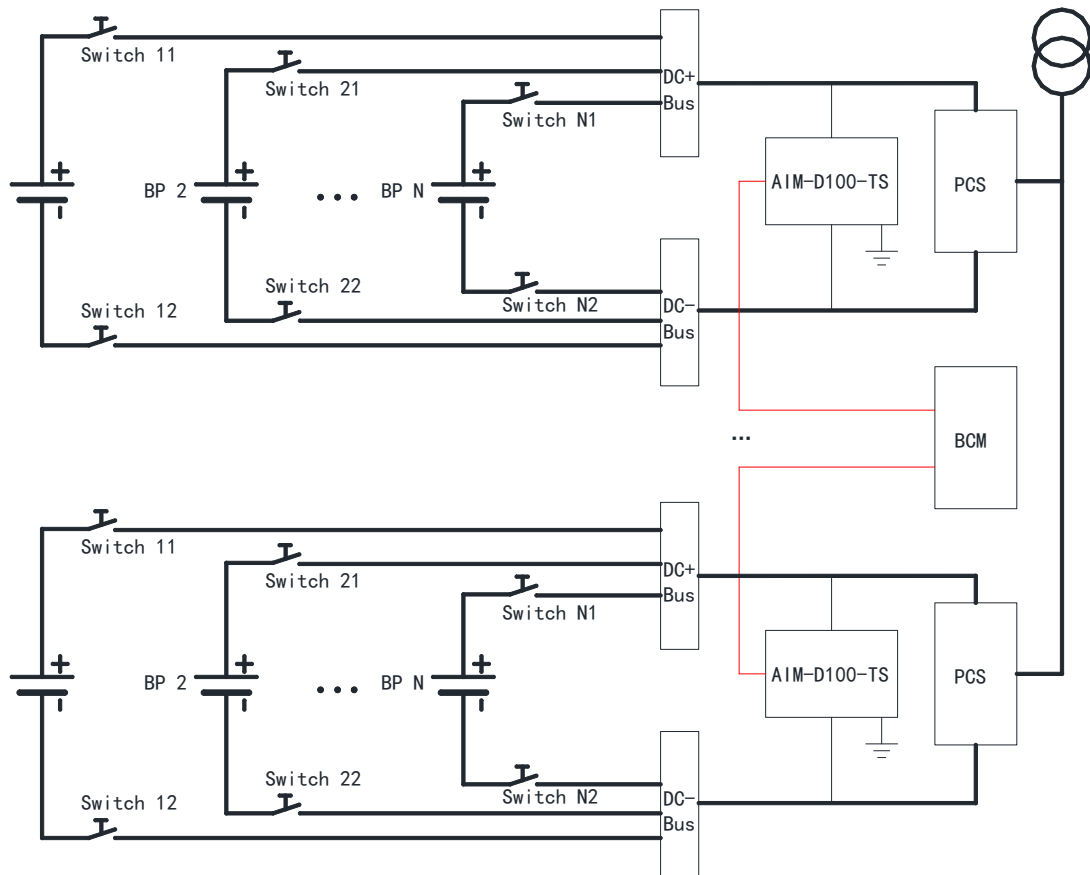

**Note:** BP stands for Battery Pack; PCS stands for Power Conversion System; BCM stands for Battery Control Module.

## 9 Fault Resolution

Make sure the wiring is correct, then turn on the meter auxiliary power. Check whether the meter is normal, for common problems, you can judge the cause and troubleshoot according to the fault phenomenon.

No.	Fault Phenomenon	Causes and Troubleshooting
1	LEDs do not light up	Check whether the meter power supply is normal. if the power supply is normal, then replace the meter.
2	Meter can't communication	(1) Check whether the communication tools are normal and whether the communication wiring A and B are correct. (2) Check the communication parameters, confirm the address, baud rate, data forma. (3) Check whether the meter is damaged or not, if the meter is damaged, then replace the met.
3	Meter communication start-up monitoring 20H show 0x8000	Reverse the positive and negative poles of the meter, replace the positive and negative wiring.
4	Meter communication start-up monitoring LED indicator flashes yellow	(1) Meter monitoring is normal, the corresponding channel insulation resistance warning, remind the site to pay attention to insulation. (2) insulation is good, judge the meter data is abnormal, 41H write 0x2710 (10s), and then start monitoring to see if the data is getting bigger, bigger than 10M, you can write 0x4E20 (20s), and then start monitoring to see if the data is normal, and so on, the capacitance time can be set to a maximum of 60s. Ref Msg: <a href="#">01 10 00 41 00 01 02 27 10 B3 7D (10s)</a> <a href="#">01 10 00 41 00 01 02 4E 20 9D 39 (20s)</a>
5	Meter communication start-up monitoring LED indicator flashes red	(1) Meter monitoring is normal, the corresponding channel insulation resistance alarm, to remind the field troubleshooting. (2) insulation is good, to determine the meter data abnormal, the same method as above.
6	Meter communication start-up monitoring Insulation data abnormal, LED normal, fault type normal	Meter insulation monitoring alarm switch off, 34H write to 0xFEFE. Ref Msg: <a href="#">01 06 00 34 FE FE 09 E4</a>



Headquarters: Acrel Co., Ltd.

Trade Company: Acrel E-Business (Shanghai) Co., Ltd.

Address: No.253 Yulv Road, Jiading District, Shanghai, China

Postcode: 201801

Manufacturer: Jiangsu Acrel Electrical Manufacturing Co., Ltd.

Address: No.5 Dongmeng Road, Dongmeng industrial Park, Nanzha Street, Jiangyin City, Jiangsu Province, China

Mobile/WhatsApp: 0086-188 6162 8731

Web-site: [www.acrel-electric.uk](http://www.acrel-electric.uk)

E-mail: [elsie.ren@email.acrel.cn](mailto:elsie.ren@email.acrel.cn)

Postcode: 214405